SHEV 6 RSV



This manual is only valid for the SHEV 6 RSV (top) in combination with the AM 830 (bottom, not included in the scope of delivery) — sample picture!

Copyright by SIMON PROtec Systems GmbH
Subject to technical changes and errors. All figures are exemplary.

SIMON PROtec Systems GmbH • Medienstraße 8 • D-94036 Passau
☎ +49 (0) 851 988 70-0 • 📠 +49 (0) 851 988 70-70 • info@simon-protec.com • www.simon-protec.com



These operating instructions are only valid with the supplied supplementary sheet „Safety instructions and Warranty conditions“!

Table of Contents

1. In General	4
1.1. Foreword to this manual	4
1.2. Product description	4
1.3. Technical information	5
1.3.1. Power supply information	5
1.3.2. Output information motor channels	5
1.3.2.a. Output-impulse load	5
1.3.3. Connection information emergency switch (HE 080 / HE 082 & HE 081)	5
1.3.4. Connection information fire alarm system (FAS)	6
1.3.5. Connection information smoke detector (RM 3000 / RM 2860)	6
1.3.6. Connection information free input I	6
1.3.7. Connection information volt free contacts "NO /C / NC"	6
1.3.8. Mechanical features	6
1.3.9. Connection and operation	6
1.3.10. Installation and environmental requirements	7
1.3.11. Registrations and certificates	7
1.3.12. Control time of analog- digital-input	7
1.3.13. Technical information lead acid battery	7
1.4. Functional description	8
1.4.1. Power supply	8
1.4.2. Emergency power supply	8
1.4.3. Control electronics	8
1.4.3.a. The control of the I/V-charge	9
1.4.3.b. The monitoring of the monitor input for sequence control (main-/ emergency-power supply operation)	9
1.4.3.c. The inspection of monitored functions (detection loops, fuse, overload etc.)	9
1.4.3.d. The activation of the load relay	9
1.4.3.e. The activation of the volt-free contacts	9
1.4.3.f. The activation of the operational status indicators (OK, FAILURE and SHE)	9
1.5. Functions	10
1.5.1. SHEV-switch reset function	10
1.5.2. Not changing settings on SW1	10
1.5.3. FAS auto reset function	10
1.6. External readout of messages	10
2. Safety Regulations	12
3. Figures	13

Table of Contents

4. Mounting	14
4.1. Wire lengths	18
5. Start UP	19
6. Fault Finding	21
6.1. Error messages	22
6.2. Troubleshooting	23
6.2.1. Checking voltages	24
6.2.2. Checking loop current	24
6.2.3. Checking power supply (230 V AC 50 Hz)	24
6.2.4. Checking motor connection (24 V DC)	25
6.2.5. Checking main emergency button (HE 080 / HE 082)	25
6.2.6. Checking smoke detector connection	27
6.2.7. Checking output for an on-site SHE release contact (for example Fire alarm)	27
6.3. FAQ — Frequently Asked Questions	29

In General

1. In General

1.1 Foreword to this manual

This manual has been created for the purposes of proper operation, installation and maintenance by trained, experienced specialist personnel (e. g. mechatronics engineer or electrician) and / or specialist personnel with knowledge involving the installation of electrical devices.

Read the operating manual carefully and follow the prescribed sequence. Retain the operating manual for later use / maintenance. Please precisely observe the pin assignment, the minimum and maximum performance data (see "Technical data") and the installation instructions. Incorrect usage or improper operation / assembly can cause the loss of system functions and result in damage to property and / or persons.

You will find the following symbols in this manual:



INFO

This information provides you with additional tips!



ATTENTION

This warning draws your attention to potential dangers for the product!



DANGER

This warning draws your attention to possible risks to your life or health!



ENVIRONMENTAL NOTE

This warning draws your attention to potential dangers for the environment!

- This is how operating procedures are identified.
- ↘ Consequences are represented this way.
- *Buttons* or *switches* to be activated are indicated in italics.
- "Displays" are placed in quotation marks.

1.2 Product description

The well known SHEV[®] 6 compact control panel system changed over for the operation with smoke and fire curtains. Without re-triggering function and a longer emergency power supply. For curtain-systems only in combination with the motor control unit called AM 830.

The electric control panel SHEV[®] 6 RSV is a compact device in a plastic housing. It contains power supply, emergency power supply and together with the AM 830 motor control unit it controls the 24 V DC-actuators for smoke and fire curtains. The SHEV[®] 6 RSV controls the connected curtains in case of fire. During a power failure, the emergency power supply ensures the performance of the curtain system for at least 60 minutes. The connection lines for SHEV-switch, smoke detector, Fire Alarm System (FAS) and actuators are monitored. The housing is lead-sealable.

Smoke and fire curtains are part of facilities technical structural fire prevention. Human lives can be saved with the installation of curtain systems. The necessity is therefore embedded by law in the national building regulations. The building permit authority decides if and in which form this legal requirement must be met. Prior to the installation, please check if the dimensions of the curtain systems are conform to the regulatory specifications to achieve a satisfactory functionality of the equipment. Through manual (switch) or automated (smoke detector / heat detector) release of the smoke and heat exhaust, curtain systems are activated, which create predefined smoke and fire sections.

In General

1.3 Technical information

1.3.1 Power supply information

Nominal voltage:	230 V AC
Acceptable voltage range:	195 V to 264 V AC
Power consumption ¹ :	1.2 A
Min. series fuse (on site):	≥ C 16 A
Connected load:	206 VA
Inrush current:	approx. 20 A
Frequency range:	47 Hz to 63 Hz
Main fuse: (internal)	Fuse characteristic: 2 × Type T 1.25 A
Power supply line cross section:	at least 1.5 mm ²
Clamp format:	0.5 mm ² - 2.5 mm ²

1. Power consumption during maximum load of the supply system.

1.3.2 Output information motor channels

Duty cycle (D):	30%
Output voltage mains operation (nominal):	24 V DC
Acceptable voltage range (mains operation):	23.0 V DC to 24.5 V DC
Output voltage (battery operation (nominal):	24 V DC
Acceptable voltage range (battery operation):	21 V DC to 28.6 V DC
Output current (I_{out}) (short-term oper- ation) ¹ : ($I_{out}=I_{mot1}+I_{mot2}$)	6 A
Power output (non-stop operation):	100 W
Power output (short-term operation):	145 W
Output fuse for actuators:	Fuse characteristic: Type T 6.3 A
Ripple of the output voltage ($0 A < I_{out} < 3 A$):	≤ 300 mVpp
Power outage bridge-over time ² :	10 ms
Clamp format:	0.5 mm ² - 2.5 mm ²

1. Overload duration (see Figure 1: "Chart output-impulse load").
2. Input voltage 195 V AC; load current 6 A.

1.3.2.a Output-impulse load

The SHEV[®] 6 RSV can be, subject to time, loaded in accordance with the following chart. The chart represents the 20 V DC output voltage limit. The output voltage should not fall below a value of 20 V DC. Therefore the impulse load can be kept in the lower quadrant of the curve (see Figure 1: "Chart output-impulse load").

Figure 1: Chart output-impulse load

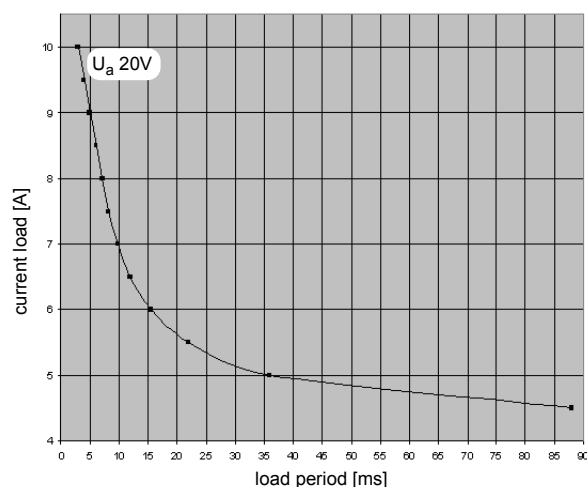

1.3.3 Connection information emergency switch (HE 080 / HE 082 & HE 081)

Maximum number of main emergency switch (e. g. HE 080 / HE 082)	1	
Maximum number of ancillary emergency switch (e. g. HE 081)	7	
Output voltage range (B1):	Clamp 7	17.5 V DC to 18 V DC
Current carrying capacity (B1):	Clamp 7	max. 120 mA
Monitoring current (OK-range)	Clamp 7	100 µA to 5 mA
Output voltage range (OK):	Clamp 1	21 V DC to 28.2 V DC
Output voltage range (Y):	Clamp 2	21 V DC to 28.2 V DC
Output voltage range (M):	Clamp 3	21 V DC to 28.2 V DC
Input voltage range (RA):	Clamp 6	15 V DC to 30 V DC

In General

Input voltage range (RZ):	Clamp 5	15 V DC to 30 V DC
Current carrying capacity (OK):	Clamp 1	max. 80 mA
Current carrying capacity (Y):	Clamp 2	max. 80 mA
Current carrying capacity (M):	Clamp 3	max. 80 mA

1.3.4 Connection information fire alarm system (FAS)

Output voltage range (B3):	Clamp 28	17.5 V DC to 18 V DC
Current carrying capacity (B3):	Clamp 28	max. 120 mA
Monitoring current (OK-range)	Clamp 7	100 µA to 5 mA
Reset time after SHEV-reset (by disconnecting from mains B3):	Clamp 28	3 sec.
Input voltage range (RA):	Clamp 30	15 V DC to 30 V DC

1.3.5 Connection information smoke detector (RM 3000 / RM 2860)

Maximum number:		8 x RM 3000 6 x RM 2860
Output voltage range (B2):	Clamp 25	17.5 V DC to 18 V DC
Current carrying capacity (B2):	Clamp 25	max. 120 mA
Monitoring current (OK-range)	Clamp 7	100 µA to 5 mA
Reset time after SHEV-reset (by disconnecting from mains B2):	Clamp 25	3 sec.
Input voltage range (RA):	Clamp 27	15 V DC to 30 V DC

1.3.6 Connection information free input I

Input voltage range (I):	Clamp 16	15 V DC to 30 V DC
--------------------------	----------	--------------------

1.3.7 Connection information volt free contacts "NO / C / NC"

Voltage capacity of switching contact 1 (C - NO):	Clamp 32 on Clamp 31	max. 30 V DC
Voltage capacity of switching contact 1 (C - NC):	Clamp 32 on Clamp 33	max. 30 V DC
Voltage capacity of switching contact 2 (C - NO):	Clamp 35 on Clamp 34	max. 30 V DC
Voltage capacity of switching contact 2 (C - NC):	Clamp 35 on Clamp 36	max. 30 V DC
Voltage capacity of switching contact 1 and 2 (C - NO resp. C - NC) – ohmic load:		max. 2 A DC
Switching power:		60 W / 62.5 VA

1.3.8 Mechanical features

Size Standard (w x h x d):	361 x 254 x 111 mm
Weight (incl. battery):	6.40 kg
Protection type:	IP66 ¹ acc. EN 60 529
Housing:	Polystorol ² Halogen-free
Colour:	grey (resembling RAL 7035)
Protection class:	Ⅰ ³

1. With the respective use of IP66 cable glands.
2. Other materials optional.
3. To achieve a higher EMC stability the protective conductor is used as functional electrical conductor and should be connected.

1.3.9 Connection and operation

Connection:	See Figure 5: "Wiring diagram total (simplified representation)" on page 15.
Terminal clamps:	Tension spring clamps 0.5 mm ² - 2.5 mm ²
Switching off the actuators in any position:	yes ¹

In General

Maximum wire length between control unit and actuator:	See chapter 4.1 "Wire lengths" on page 18.
Opening-/closing process:	Pole reversal of the operating voltage
Pause time during direction change:	200 ms
Maintenance:	See chapter 7. "Care and Maintenance" on page 30.

1. Only during ventilation operation.

1.3.10 Installation and environmental requirements

Operating temperature ¹ :	-5 to 40 °C
Storage temperature ¹ :	-5 to 40 °C
Suitable for outdoor installation:	No

1. This temperature range applies to all components of the SHEV® 6 RSV-System (including battery).

1.3.11 Registrations and certificates

EN compliant:	As per EMC directive 2004 / 108 / EC and the low-voltage directive 2006 / 95 / EC
Additional registrations, certificates ¹ :	ISO 21927-9 prEN 12101-9 DIN EN 12101-10
Classification as per EN 12101-9 ¹ :	Class D
Classification as per EN 12101-10 ¹ :	Class A
Environmental class as per EN 12101-10 ¹ :	1

1. These registrations are in progress.

1.3.12 Control time of analog- digital-input

Input digital (RZ, RA, LZ, Z, A):	500 ms
Input analog (B1, B2, B3) during mains operation:	500 ms
Input analog (B1, B2, B3) during emergency power operation:	2500 ms

1.3.13 Technical information lead acid battery

Maintenance-free lead acid battery	
Dimensions (w x h x d):	171 x 33 x 60 mm
Weight incl. installation plate:	2.20 kg
VdS registration:	G101139
Output voltage per battery:	10.5 V DC to 14.1 V DC
Output voltage total (series connection):	21.0 V DC to 28.2 V DC
Rated capacity (total):	2.3 Ah
Service life:	approx. 4 years

In General

1.4 Functional description

The SHEV® 6 RSV is an application of the SHEV® 6 compact control panel system for the usage with automatical curtain systems

In the standard version it is housed as a compact assembly group in a single board system in a surface-mounted housing.

The SHEV® 6 RSV forms together with the motor control unit AM 830 an unit to control automatically smoke and fire curtains.

The requirements involved are the connection option of all necessary tripping devices such as:

- smoke detector,
- SHEV-emergency button,
- fire alarm-signal

and the triggering of the AM 830 motor control unit.

The SHEV® 6 RSV essentially consists of three components:

1. power supply
2. emergency power supply
3. control electronics

1.4.1 Power supply

If the SHEV® 6 RSV is connected to the mains and supplies the necessary power from the mains, then this is considered normal operations (mains operation). The power supply is designed in such a manner that it can meet the power demand of the control technology, the battery charging and can provide power for the connected actuators. It is built as a switching power supply.

The power supply is sustained short circuit-proof, sustained no-load running-proof and is safeguarded by a complying fuse. The power supply is exclusively cooled by natural air cooling.

1.4.2 Emergency power supply

The emergency power supply of the SHEV® 6 RSV is ensured by two 12 V lead acid batteries, which are series connected.

During emergency power operation, these take over the power supply of the control electronics and the connected AM 830 motor control unit. The battery capacity is adjusted to the power supply output range and is regulated by the individual discharge phases (VdS 2593 / DIN EN 12101-10). The switching between the two operation states is automated. The load output for the AM 830 motor control unit is represented by two heavy load relays that operate using the pole reversal technique to ensure the OPEN / CLOSED control. The outputs are protected by a corresponding fuse.

During the emergency power operation, appropriate currents are to be supplied in various phases.

Upon conclusion of this discharge, the discharge threshold voltage and the under-voltage limit should not be reached.

The emergency power holding time is set to the maximum value of one hour (3600 seconds) factory-provided. Via USB-300 and SIMON-Link it can be set to a lower value.

1.4.3 Control electronics

The complete control of the SHEV® 6 RSV is assumed by a microcontroller.

The control functions consist of:

- a. the control of the I/V-charge,
- b. the monitoring of the monitor input for sequence control (mains-/emergency power supply operation),
- c. the inspection of the monitored functions (detection loops, fuse, overload, etc)
- d. the activation of the load relay
- e. the activation of the volt-free contacts
- f. the activation of the operational status indicator (OK, ERROR and SHE)

In General

1.4.3.a The control of the I/V-charge

The charge of the lead acid backup-battery is accomplished in the form of a I/V-charge. This means that the charging current is bound to a constant current. If the battery voltage reaches the charge threshold voltage, then this voltage will be limited, by reducing the charging current. According to the manufacturer's data, the charging voltage is influenced by the ambient temperature, which means that the charge threshold voltage decreases when the ambient temperature increases, the reverse applies accordingly when the ambient temperature drops. The charging circuit is designed in such a way that 80% of the battery capacity can be charged within 24 hours, after the battery was discharged at its discharge threshold voltage. This conforms to the DIN EN 12101-10 requirement. To inspect the condition of the connected battery, the charge is turned off for a short time in intervals of approximately 8 minutes. The condition of the battery is inspected during this charging break. Meanwhile for example a disconnected battery will be detected and indicated as an error. Should the battery pair fault due to the cells becoming high-ohmic, then the control will also detect this and inform the facility operator with a fault message at the SHEV-switch (yellow LED).

The detailed fault message can be read-out via service-cable (USB-300) and SIMON-Link.

1.4.3.b The monitoring of the monitor input for sequence control (main-/ emergency-power supply operation)

If there is a power outage or under-voltage of the power supply, or a power supply failure, then the SHEV® 6 RSV switches to the emergency power supply. This is done with the help of monitoring (monitor function). Thereby the control electronics can switch to emergency power operation at an early stage and avoid an output voltage disruption.

1.4.3.c The inspection of monitored functions (detection loops, fuse, overload etc.)

The control electronics monitor the tripping devices SHEV-switch, smoke detector and FAS with a no-load current surveillance. This means that a permanent no-load current flows over the tripping devices. This is secured by the terminating resistors in the last tripping device. Once the closed-circuit current leaves a certain range of values (current window), the relevant detection line will trigger the SHEV-state. To get to the normal operation from the SHEV-state, a reset must be executed (see chapter 1.5.1 "SHEV-switch reset function" on page 10).

1.4.3.d The activation of the load relay

All SHEV® 6 RSV outlets are equipped with an overload protection. During emergency power operation all relays de-energize after 60 minutes (maker opens again and breaker closes).

1.4.3.e The activation of the volt-free contacts

During emergency power operation all relays de-energize (maker opens again and breaker closes). Depending on wiring, "volt-free contact" can be output by the error relay (see Table 1: "Matrix signal relay (Contact 1, Contact 2)" on page 11).

1.4.3.f The activation of the operational status indicators (OK, FAILURE and SHE)

The SHEV® 6 RSV has three operational status indicators on the control board to display the actual operation mode (see chapter 6.1 "Error messages" on page 22).

- The green LED indicates mains operation.
- The yellow LED serves as status or fault indicator.
- The red LED indicates SHEV-alarm.

In General

1.5 Functions

Figure 2: DIP switch SW1

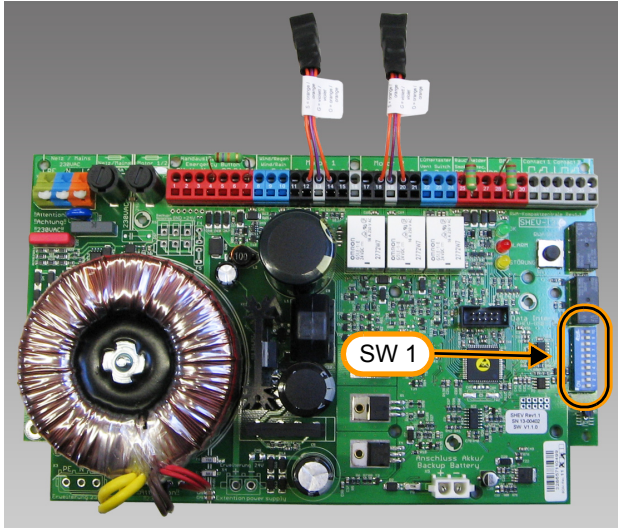

1.6 External readout of messages

The SHEV® 6 RSV is equipped with two volt-free relays or contacts to redirect fault messages. The user can select the allocation of the message using a DIP-switch 5 - 8 at SW1 on the SHEV® 6 RSV board (see Table 1: “Matrix signal relay (Contact 1, Contact 2)” on page 11).

1.5.1 SHEV-switch reset function

The SHEV-message can be reset by the *SHEV-switch*. Only the SHEV-message is reset when the *RESET-switch* is operating the first time.

If a SHEV-alarm is present at detection loop 2 or 3 at this stage, then this message is blocked out for 3 seconds when the RESET switch is operated. Additionally, the detection loops 2 and 3 are switched off for this same amount of time.

By operating the *RESET-switch* twice, the via AM 830 motor control unit connected curtain upwinds.

1.5.2 Not changing settings on SW1

For an accurate function of the system the DIP-switches 1 to 4 (ventilation settings) and 9 (FAS alarm closes) should be set on OFF.

1.5.3 FAS auto reset function

Upon the triggering by fire alarm-contact (High Signal or disconnection of B1), the message is cancelled again by the FAS-reset function when the signal is changed or the disconnection is lifted. The function can be switched on or off via the DIP-switch 10 at SW1. If the DIP-switch is set on ON, then the FAS Auto-Reset is activated, if the switch is set on OFF, then the function is inactive.

When the FAS-Auto Reset function is utilized, the FAS-contact must be connected to the detection loop 3.

In General

Table 1: Matrix signal relay (Contact 1, Contact 2)

SW1 - 5	SW1 - 6	SW1 - 7	SW1 - 8	Allocation contact 1	Allocation contact 2	Remarks
OFF	OFF	OFF	OFF	Message SHE released – curtain drop (Alarm)	Fault (see chapter 6.1 “Error messages” on page 22)	Delivery state
ON	OFF	OFF	OFF	Message SHE released – curtain drop (Alarm)	Curtains triggered in UNWIND-direction	
OFF	ON	OFF	OFF	Message SHE released – curtain drop (Alarm)	Curtains triggered in UPWIND-direction (normal operation)	
ON	ON	OFF	OFF	Message SHE released – curtain drop (Alarm)	Central UPWIND active (normal operation)	
OFF	OFF	ON	OFF	Message SHE released – curtain drop (Alarm)	OK	Power supply ok and no wire break on motor line 1 / 2
ON	OFF	ON	OFF	Fault (see chapter 6.1 “Error messages” on page 22)	Curtains triggered in UNWIND-direction	
OFF	ON	ON	OFF	Fault (see chapter 6.1 “Error messages” on page 22)	Curtains triggered in UPWIND-direction (normal operation)	
ON	ON	ON	OFF	Fault (see chapter 6.1 “Error messages” on page 22)	Curtains triggered in UPWIND-direction (normal operation)	
OFF	OFF	OFF	ON	Fault (see chapter 6.1 “Error messages” on page 22)	OK	Power supply ok and no wire break on motor line 1 / 2
ON	OFF	OFF	ON	Curtains triggered in UNWIND-direction	Curtains triggered in UPWIND-direction (normal operation)	
OFF	ON	OFF	ON	Curtains triggered in UNWIND-direction	Curtains triggered in UPWIND-direction (normal operation)	
ON	ON	OFF	ON	Curtains triggered in UNWIND-direction	OK	Power supply ok and no wire break on motor line 1 / 2
OFF	OFF	ON	ON	Curtains triggered in UPWIND-direction (normal operation)	Central UPWIND active (normal operation)	
ON	OFF	ON	ON	Curtains triggered in UPWIND-direction (normal operation)	OK	Power supply ok and no wire break on motor line 1 / 2
OFF	ON	ON	ON	Central UPWIND active (normal operation)	OK	Power supply ok and no wire break on motor line 1 / 2
ON	ON	ON	ON	Message SHE released – curtain drop (Alarm)	Message FAS released – curtain drop (Alarm)	

Safety Regulations



ATTENTION

Status messages are not displayed while emergency power operations.

The indication relays are reset to the basic position (break contact closed). Please note the operation / triggering in / while emergency power operations (see chapter 1.4.3.e "The activation of the volt-free contacts" on page 9).



INFO

With configuration of the indication relay with fault / failure the signal of the relay contacts are inverted:
failure ⇒ closing contact opened.

no failure ⇒ closing contact closed.

Possible applications:

OK = closing contact is closed = power supply ok and motor line 1 / 2 ok. (mains monitoring)

OK off = wire break on motor line 1 or 2

2. Safety Regulations

FOR THE SAFETY OF PERSONS IT IS IMPORTANT TO FOLLOW THESE INSTRUCTIONS. THESE INSTRUCTIONS ARE TO BE KEPT AND HANDED TO THE CUSTOMER FOLLOWING INSTALLATION AND COMMISSIONING.



DANGER

Do not allow unauthorised persons (e. g. children) to operate permanently installed control panels. Keep remote controls out of reach of unauthorised persons.



DANGER

The actuating element of switches with an 'off' presetting must be installed in a place with a direct line of sight to the driven part, but away from moving parts. If it is not a key switch, it must be installed at a height of at least 1.5 m and must be inaccessible to the public.



DANGER

Please consider VDE 0833 for hazard alert systems, VDE 0100 for electrical systems, DIN 18232 for SHEV systems, the local fire department regulations, the energy supply company regulations for the mains connection as well as BGV A3 and the BG regulation BGR 232. All relevant national safety regulations and rules apply to the bringing onto the market, installation and commissioning of the equipment outside the country of manufacture (Germany).



DANGER

Free access must be ensured to the energy supplies and electrical control panels of SHEV systems.



DANGER

The sign for the manual release must be attached permanently in the vicinity of its actuating element.

Figures

3. Figures

Figure 3: Block diagram

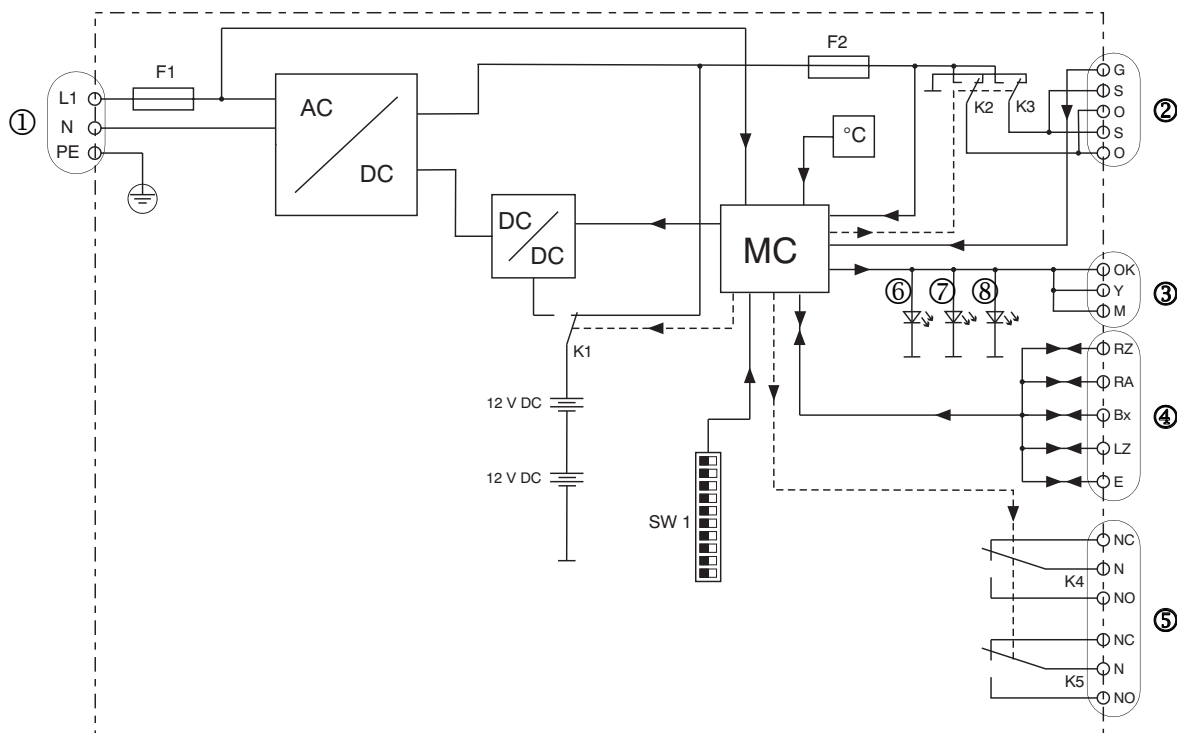

Legend:

- SW 1 DIP switch setting SHEV
- F1 fuse, mains
- F2 fuse, motor
- K2, K3 pole reverse relay
- K4, K5 indication relays
- ① mains
- ② motor 1 / motor 2
- ③ messages for switch
- ④ tripping devices
- ⑤ detector signalling contacts
- ⑥ LED "OK"
- ⑦ LED "Alarm"
- ⑧ LED "Fault"

Mounting

4. Mounting



DANGER

Mounting may be carried out only by professional personnel (qualified electrician)! All relevant national safety regulations and rules apply to mounting, installation and commissioning.

If the installation is not carried out correctly there is a danger of electrocution. It is essential that you adhere to the applicable safety regulations! Pay attention to the valid installation regulations. Incorrect installation can lead to serious injuries.

The position of installation of the SHEV[®] 6 RSV is subject to the position of the battery. The batteries can be installed in all positions except overhead.



ATTENTION

The openings of the battery cells (round lid on the top side of the batteries) should not point downwards. As improper care of the batteries will lead to gel leakage from the battery!



ATTENTION

Do not ever connect the battery during installation!

- Mark the position of the drilling holes (see Figure 4: "Fastening points housing").
- Make drilling holes.
- Fasten the SHEV[®] 6 RSV with six, subsurface suitable screws (screws are not included in the scope of delivery) through the housing bottom.

Figure 4: Fastening points housing

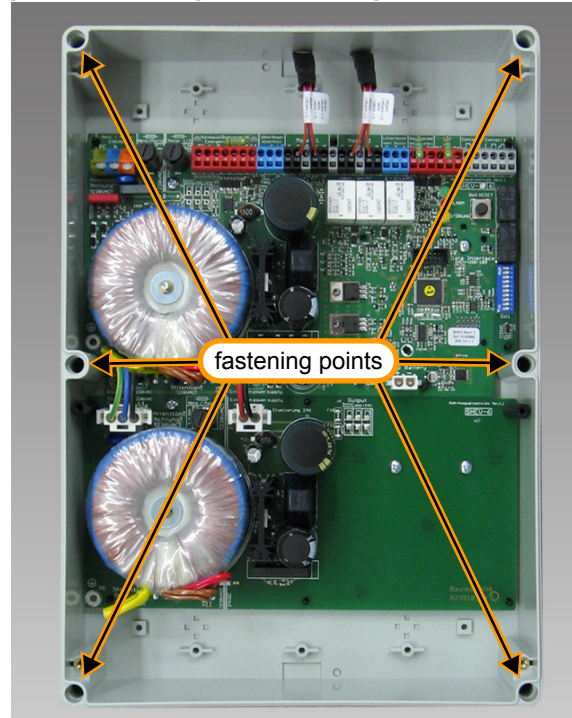

DANGER

Disconnect the power supply cord for all poles from the mains. The connection of the SHEV[®] 6 RSV must be done volt-free!

- Lead the power supply cords through the prepunched openings.
- Connect cords according to wiring diagram. (see Figure 5: "Wiring diagram total (simplified representation)" on page 15) and the subsequent wiring diagrams.
- Remove the terminating resistors of the SHEV-switch, smoke detector and the FAS-contacts from the clamps of the central unit and connect to the triggering devices.



ATTENTION

The indicated protection type IP 66 only remains if the appropriate running of cables resources are employed.

Mounting

Figure 5: Wiring diagram total (simplified representation)

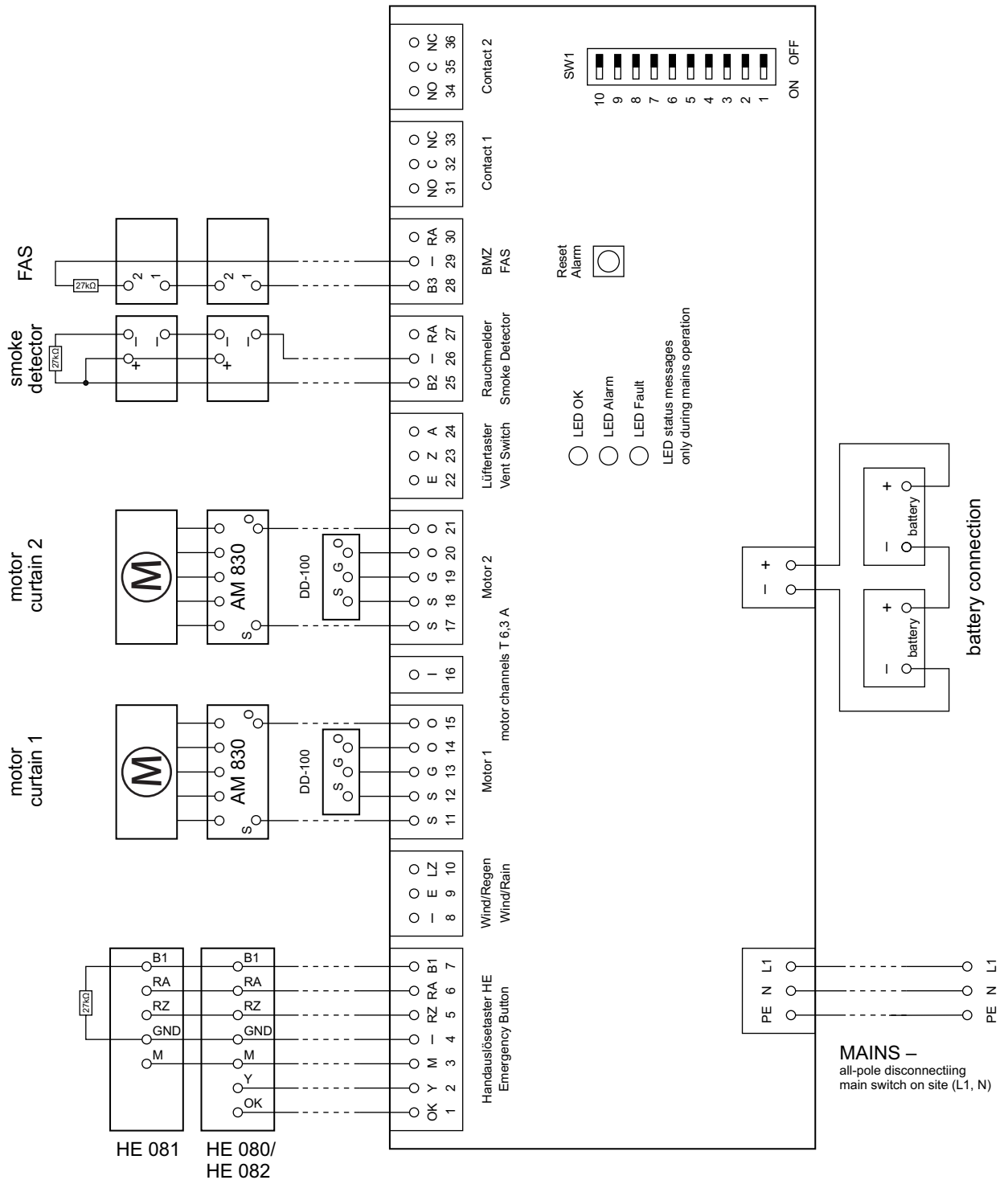

Mounting



ATTENTION

For maintenance purposes install an all-pole mains switch (N, L1) before the SHEV® 6 RSV.

Figure 6: Wiring diagram mains

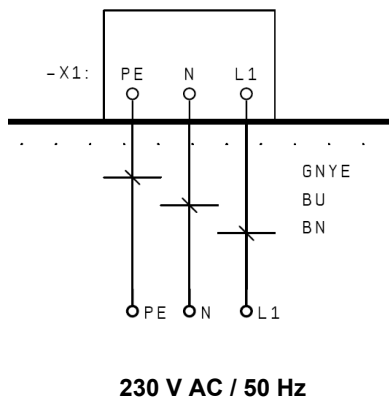
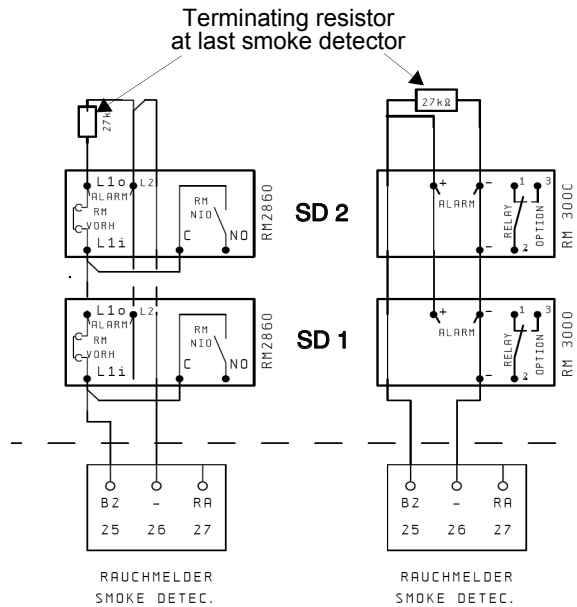

Figure 7: Wiring diagram smoke detector

RM 2860 alternatively RM 3000



INFO

The use of shielded wires is recommended for the detection loops. The insulation resistance must display at least 20 MΩ/km. Manufacturer's technical information are to be observed when the wires are laid.

Figure 8: Wiring diagram SHEV-switch

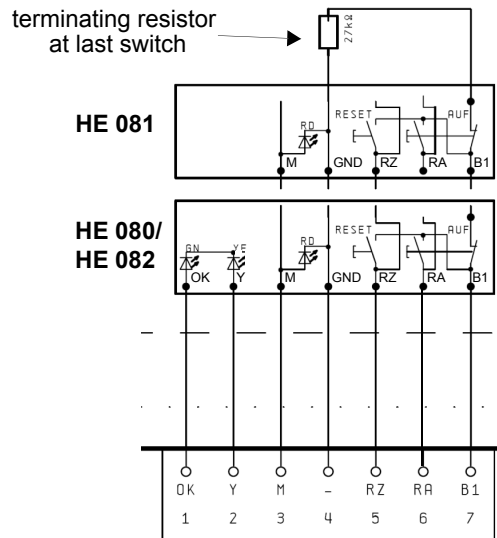

Mounting

Figure 9: Wiring diagram single roller

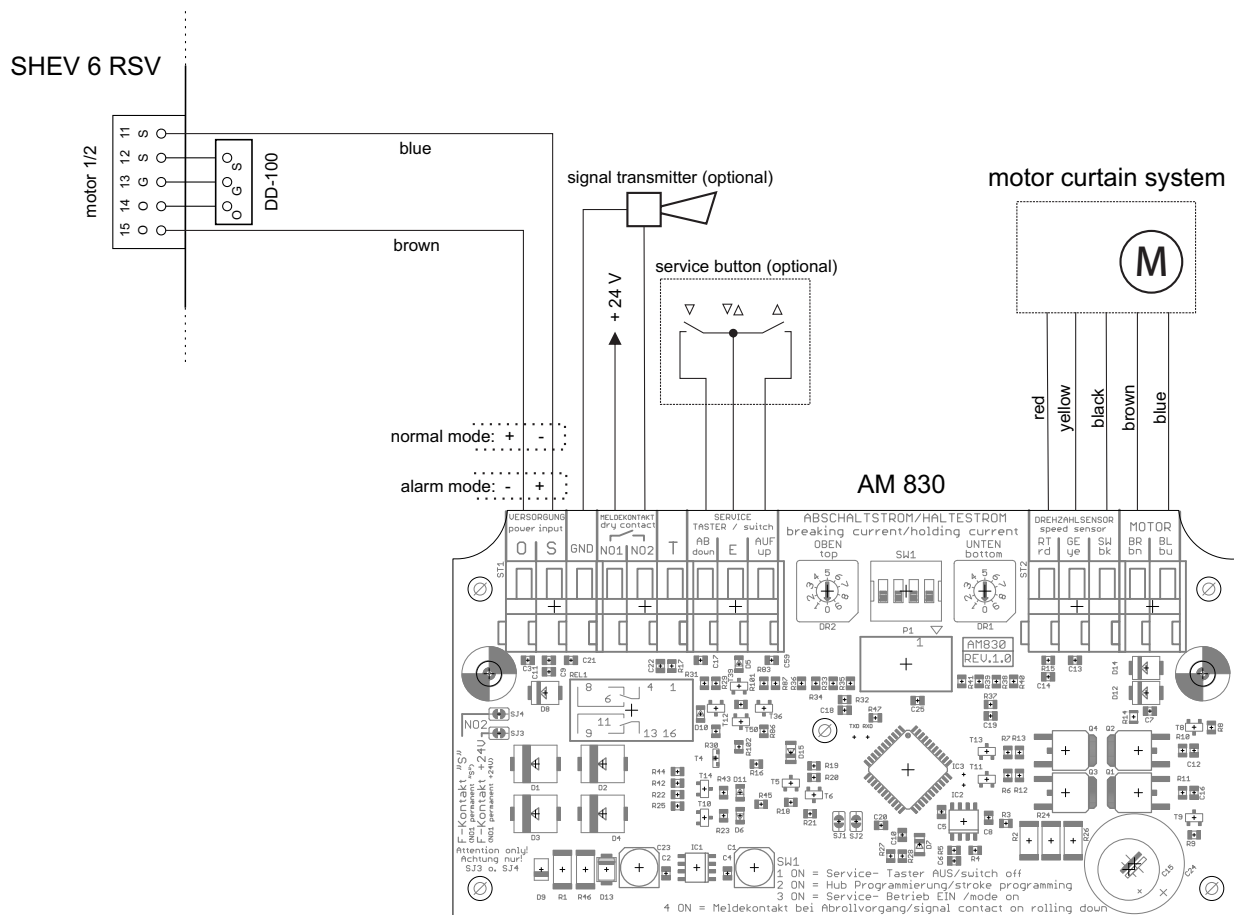
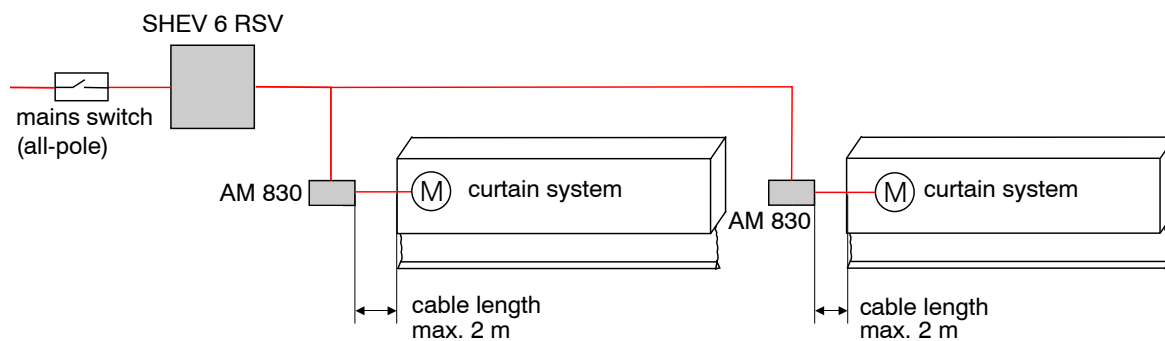

Figure 10: Connection diagram single roller via central power supply



Mounting

Figure 11: Connection diagram multiple roller¹

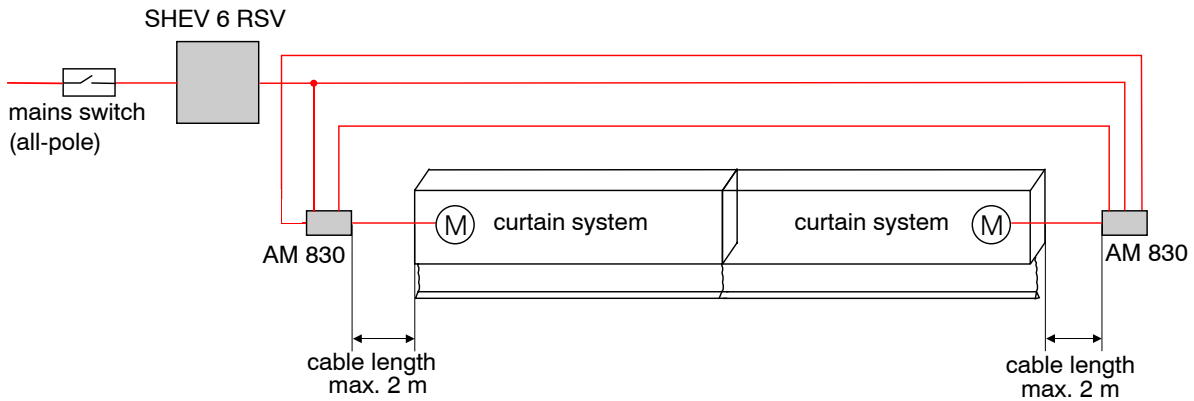
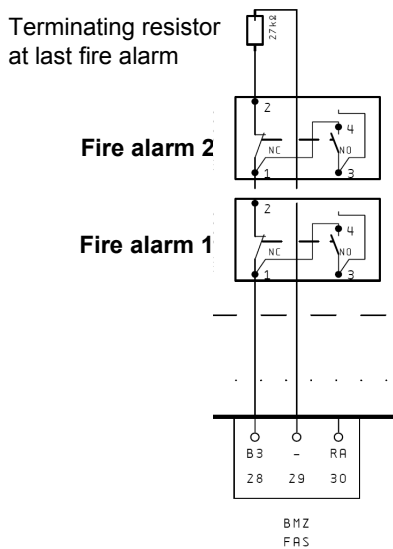

Figure 12: Wiring diagram contact FAS



4.1 Wire lengths

INFO

Dimension indications (rule of thumb):

$$\text{Wire cross-section [mm}^2\text{]} := 0.019 \times \text{number of motors} \times \text{power consumption per motor [A]} \times \text{wire length [m]}.$$

The national regulations are valid.

1. For the connection of the communication wires between the AM 830 control modules please check the operating manual of the AM 830.

Start UP

5. Start UP



ATTENTION

The battery must only be mounted and connected once the start up of the SHEV[®] 6 RSV is executed successfully and the on-site power supply has been permanently secured.

- Execute start up. Prior to turning on the SHEV[®] 6 RSV, you must perform the following visual and functional checks (see Figure 13: "Start up – checklist").

Figure 13: Start up – checklist

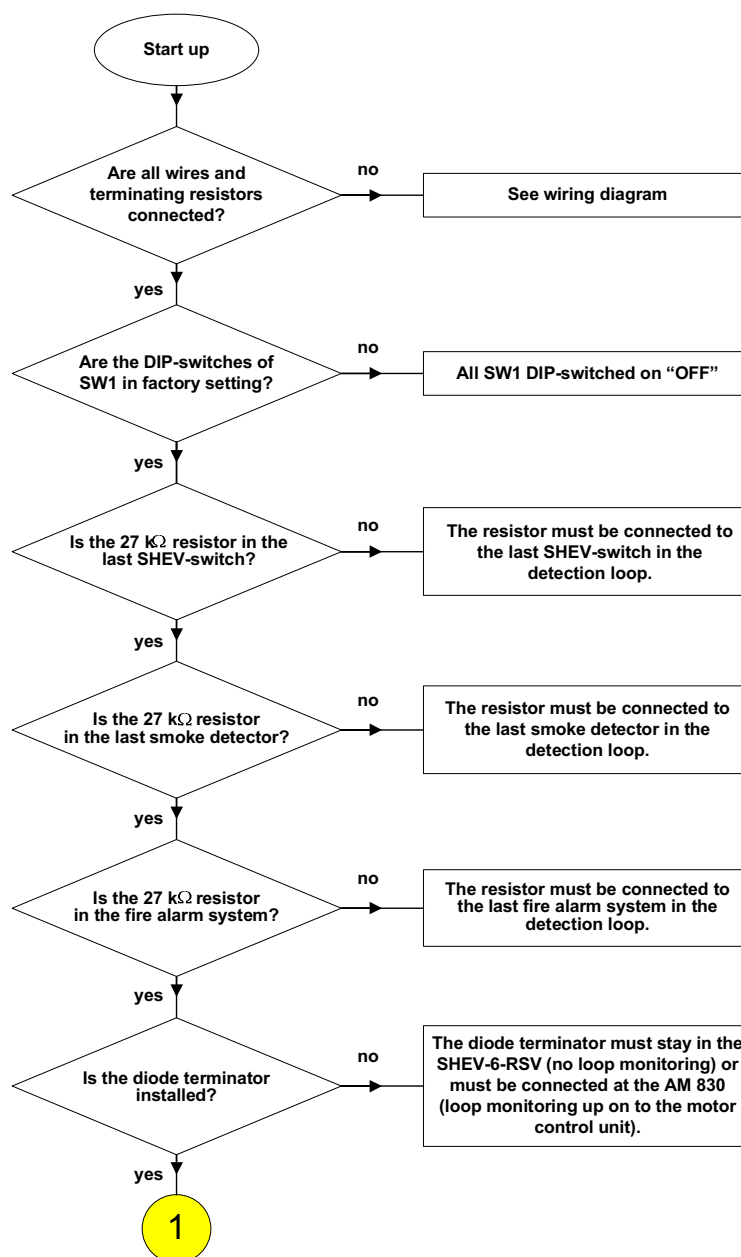

Start UP

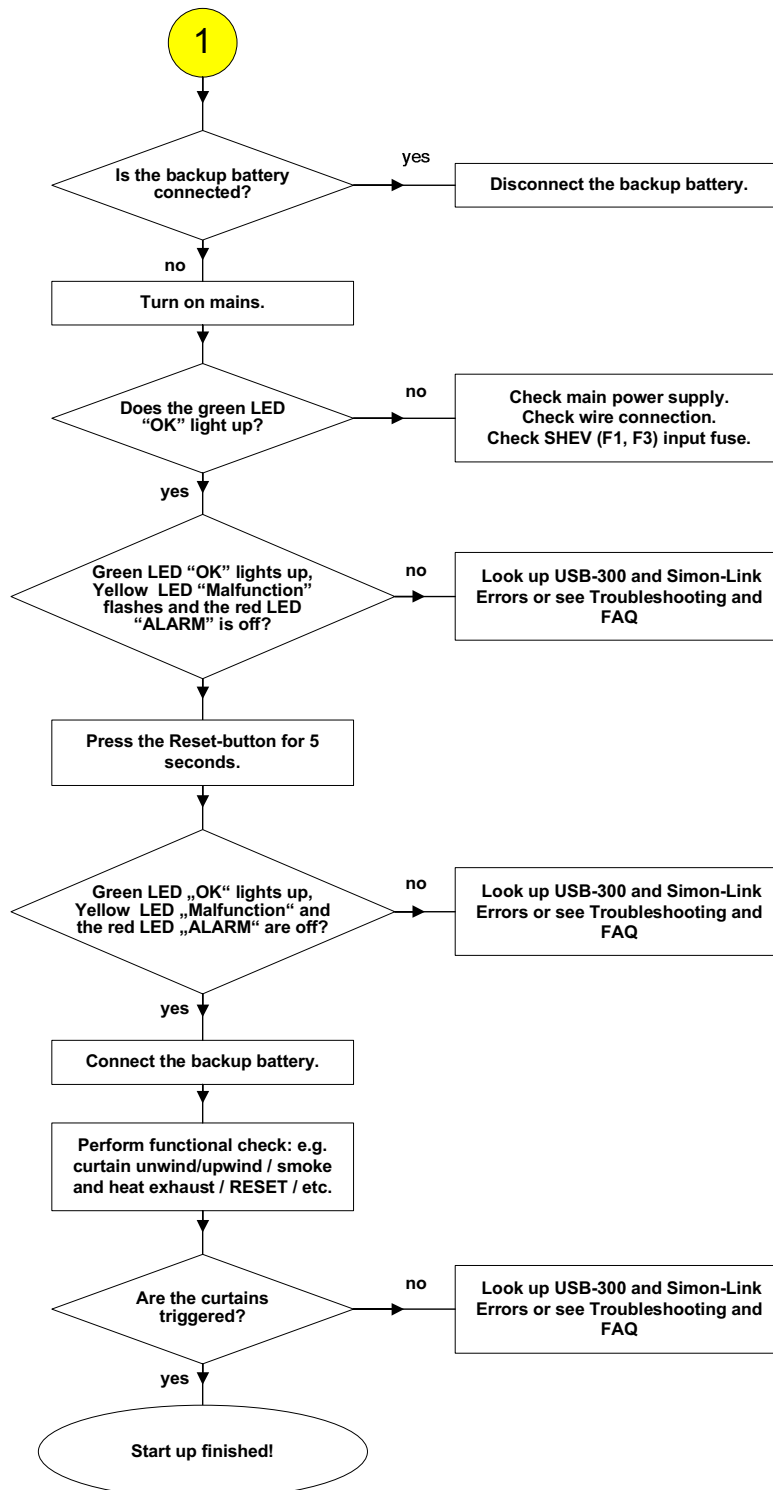

Fault Finding



ATTENTION

If mains is not permanently guaranteed after installation, there is a big risk of deep discharge of batteries! This will lead to damage to the battery.



INFO

The error message can potentially only appear after 8 minutes if the battery fails.



ATTENTION

Only batteries approved by panel manufacturer are allowed for connection. The control panel lose the relevant certifications if any other battery is used. The warranty expires.

- Connect battery plug to the port "Battery" (see Figure 14: "Battery connection").

Figure 14: Battery connection

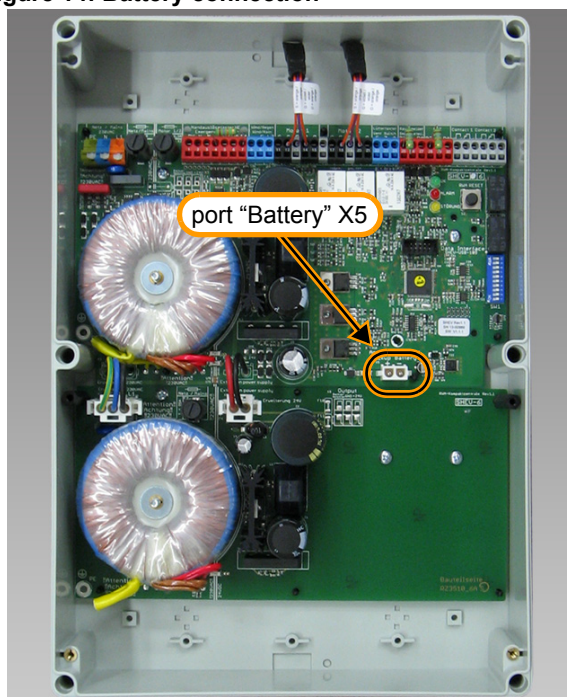

- Fasten the battery with 4 screws M4 x 8 mm (screws are included in the scope of delivery).

Figure 15: Befestigungspunkte Akku

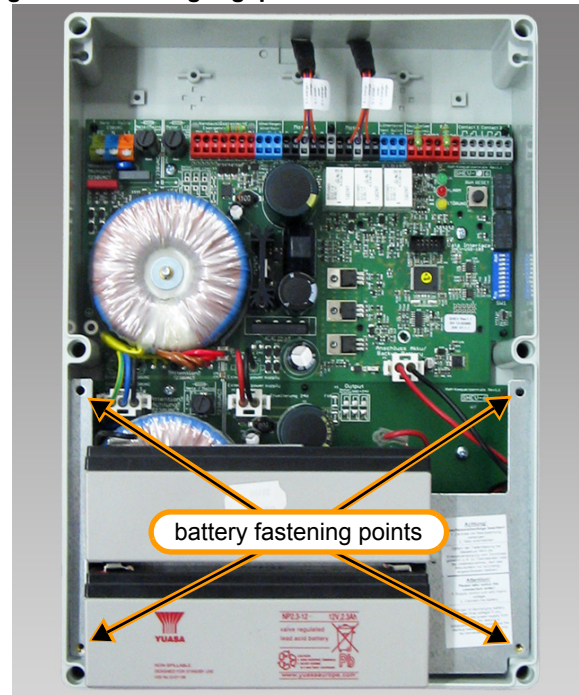

6. Fault Finding



ATTENTION

Due to the low loop current, the insulation resistance of the monitored wires (B1, B2 and B3) must be checked! The insulation resistance must be $> 20 \text{ M}\Omega/\text{km}$ (wire manufacturer specification), otherwise interruptions will no longer be detected for certain.



INFO

The operation states of the SHEV[®] 6 RSV can be visualized optional by a Service Interface / cable (USB-300) (only during mains operation.) More Information: www.simon-protec.com.



Fault Finding

6.1 Error messages

Table 2: SHEV® 6 RSV fault indications

green LED on, yellow LED on, red LED off;	green LED flashes, yellow LED on, red LED off;	green LED off, yellow LED on, red LED off;	green LED on, yellow LED off, red LED on;	green LED on, yellow LED on, red LED on;	green LED flashes, yellow LED off, red LED off.
load fuse F2 defect	battery defect (high-ohmic state)	wire break motor channel 1	SHE-alarm / curtain drop triggered by RA input	overload, short circuit, disconnections at the outputs B1, B2, B3	system awaits 2nd reset-switch activation after SHEV-alarm.
the battery reaches the deep discharge.	no battery connected	wire break motor channel 2			
	short circuit at charge output and battery connection				



INFO

The SHEV® 6 RSV indications are only visualized during mains operation.

Table 3: Fault indication at the main emergency switch (HE 080 / HE 082)

green LED off, yellow LED flashes, red LED off;	green LED on, yellow LED flashes, red LED off;	green LED flashes, yellow LED flashes, red LED off;	green LED on, yellow LED off, red LED on;	green LED on, yellow LED flashes, red LED on;	green LED flashes, yellow LED off, red LED off.
emergency power operation (caused by mains power outage and undervoltage at the mains input respectively).	Load fuses defect	battery defect (high-ohmic state)	SHEV-alarm / curtain drop triggered by RA input	overload, short circuit, disconnections at the outputs B1, B2, B3	system awaits 2nd reset-switch activation after SHEV-alarm
power supply fuse F1 defect		short circuit at charge output and battery connection			
failure of the 24 V switching power supply					

Fault Finding

Table 3: Fault indication at the main emergency switch (HE 080 / HE 082)

green LED off, yellow LED flashes, red LED off;	green LED on, yellow LED flashes, red LED off;	green LED flashes, yellow LED flashes, red LED off;	green LED on, yellow LED off, red LED on;	green LED on, yellow LED flashes, red LED on;	green LED flashes, yellow LED off, red LED off.
reaching final discharge voltage by extended emergency power operation	reaching of the deep discharge voltage	no battery connected			
deep discharge voltage reached.					
wire break motor channel 1					

6.2 Troubleshooting

Table 4: Overview of errors

Malfunction	Possible Causes	Error correction
The system unwinds the curtain immediately, the red LED is on and the yellow LED in the emergency button (type HE 080/082) flashes.	<ul style="list-style-type: none"> - Monitor loop not closed; - Short circuit monitor line B1, B2, B3. 	<ul style="list-style-type: none"> - Check terminating resistors HE / RM / FAS (B1, B2, B3) - Monitor loop must be closed; check voltage
The system faults, yellow LED in the emergency button (type HE 080/082) flashes.	<ul style="list-style-type: none"> - Fuses defect; - Mains power unavailable; - line termination of the motor wire defective. 	<ul style="list-style-type: none"> - Check all fuses of the control device; - Check mains connection; - Check line termination of the motor wire.
The system has AC power (green LED on) but remain in the fault mode (yellow LED flashes) and can not be reset normally.	<ul style="list-style-type: none"> - Reaches battery deep discharge; - Start up (respectively in the meantime no battery connected). 	<ul style="list-style-type: none"> - Check the battery, replace if necessary; - To reset the error messages press the reset-button for more than 5 seconds.
The motor fuse blows, yellow LED in the emergency button (type HE 080/082) flashes; the green and red LED are off.	<ul style="list-style-type: none"> - Line termination of the motor wire incorrectly connected; - F-contact of motor connected to G. 	<ul style="list-style-type: none"> - Check connection of the line termination of the motor wire. Do not connect clamp "G" with the terminal clamp "F" of the motor.
The curtain has the wrong running direction.	<ul style="list-style-type: none"> - Terminal clamps "+/-" interchanged; S =blue; O = brown 	<ul style="list-style-type: none"> - Check connection between SHEV® 6 RSV and motor control unit AM 830; - Check connection between motor and motor control unit AM 830.
Curtain switch function incorrect (only in normal mode);	<ul style="list-style-type: none"> - connections Z, A interchanged; - potential FAS CLOSED command shuts in setting FAS; or disconnection FAS 	<ul style="list-style-type: none"> - Swap Z, A at ventilation connection.
Mains voltage 230 V AC available, no LED is on.	<ul style="list-style-type: none"> - Mains fuse F1 defect 	<ul style="list-style-type: none"> - Check fuse, replace if necessary.

Fault Finding

Table 4: Overview of errors

No current at connection "E".	- Mains fuse F1 defect - System in emergency power operation - Overload at E (ventilation switch) of > 15 mA or overload at E (WTS) of > 150 mA	- Check fuse, replace if necessary. - Check mains voltage
The curtain system is not working.	- Load fuse F2 defect	- Check fuse, replace if necessary.
Green LED flashes and yellow LED is on.	- Battery defect, battery high-ohmic or battery not connected	- Check battery and switch if necessary.
Failure of the +24 V power supply.	- function-failure	- Press RESET-button (> 5 seconds). Attention! If the failure still exist +24 V power supply is defect.

6.2.1 Checking voltages



ATTENTION

The components must be connected and the last component must be equipped with the terminating resistor.

Check fuses if a voltage indicates a value other than the given.

If no change happens after this, disconnect all loads and monitored loops and connect the terminating resistors and diode terminator in the SHEV® 6 RSV to all monitored loops.

If the voltage values correspond with the specifications, then one of the connected loads is causing an overload at the connections: "E", "B1", "B2", "Y", "OK", "M" or "B3".

Connect the loads again in sequence and check the respective output voltage each time again. Subsequently check the number of the loads and faultless performance. If the voltage values still do not correspond with the given values even after disconnecting all loads, then the control panel must be checked in the factory.

6.2.2 Checking loop current

The control panel is automatically triggered if the value of monitoring current is too high or too low. Should the SHEV® 6 RSV still be automatically triggered despite closed loops, given current, then the SHEV® 6 RSV must be checked in the factory. Replace the used terminal resistors and diodes to make sure they are faultless.



DANGER

There is a risk of electric shock. Therefore, the tests should only be carried out by experienced and qualified personnel (The national regulations are valid).

6.2.3 Checking power supply (230 V AC 50 Hz)

Figure 16: Mains voltage

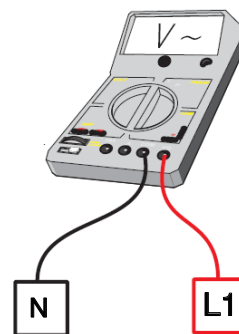

- During mains operation: approx. 230 V AC.
- Green LED "OK" on.
- Is the yellow LED "Fault" on (see Table 2: "SHEV® 6 RSV fault indications" on page 22).

Fault Finding

6.2.4 Checking motor connection (24 V DC)



Motor output: 24 Volt DC. Defected or missing fuses will be indicated as a fault!



ATTENTION

Only fuses with a “slow” triggering characteristic should be used.

Figure 17: Voltage motor connection

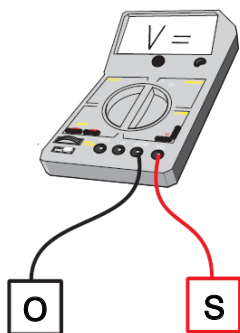

- Only during selection of “OPEN” or “CLOSED”:
- During mains operation approx. 24 V DC.
- During emergency power operation approx. 21 V DC to 28.6 V DC

The polarity in the terminal clamps “S” and “O” switches during selection of “OPEN” and “CLOSED”. With the switch setting “OPEN”, the terminal clamp “S” is plus potential and the terminal clamp “O” is minus potential. The monitoring loop is connected to the terminal clamp “G”. When the motor wires are faultless and the control panel is polarized in the “OPEN” direction, a closed-circuit current of 160 μ A to 180 μ A in the “G” wire can be measured.

The same closed-circuit current value applies to “S” and “G” for polarization in the “CLOSED”-direction.

The accompanying diode terminator must be installed at the last connection point of the motor supply wire loop as shown in the connection illustration. There will be a fault message at the main emergency switch HE 080 / HE 082 and SHEV® 6 RSV if there is an error with the wire!



ATTENTION

There is no fault message when the diode terminator is clamped into the central unit – the motor wires, however, are not monitored.

Figure 18: Loop current motor connection

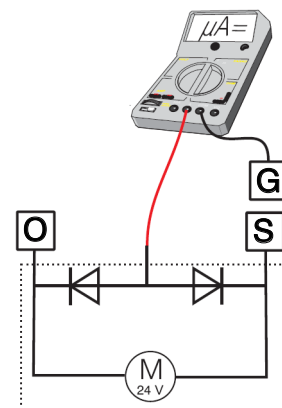

- Closed-circuit current in the wire between “G” and “purple wire” at the diode connection (monitoring loop – motor wire):
- between 160 μ A and 180 μ A.

6.2.5 Checking main emergency button (HE 080 / HE 082)

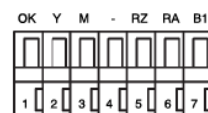

As basis for all signaling connections, the minus potential of the terminal clamp “-” applies. Terminal clamp “OK” supplies a plus potential approx. 24 V, should there be no fault with the control panel. The green LED is connected between “OK” and “-”. The connection “OK” is safeguarded by a short-circuit protection.



ATTENTION

Do not connect more than 1 main emergency switch

Fault Finding

Figure 19: Voltage at main emergency switch "OK"

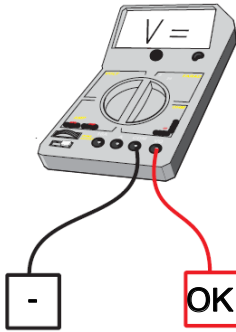

- during mains operation approx. 24 V
- during emergency power operation approx. 21 V DC to 28.6 V DC.

"Y" supplies a plus potential against minus for the fault display. The signal is a continuous signal that is converted to a blinking signal by electronics on the main emergency switch. The yellow LED is connected between "Y" and "-".

Figure 20: Voltage main emergency switch connection "Y" (fault)

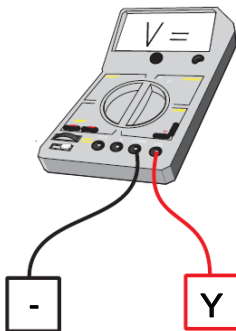

- Only during fault:
 - During mains operation: approx. 24 V DC.
 - During emergency power operation: approx. 21 V DC to 28.6 V DC.

"M" supplies a plus potential during "SHE OPEN" (HE, RM, TH, FAS). The red LED alarm is connected between "M" and "-". This output can service max. 8 OPEN-displays of the control units in parallel. If more than 8 switches are connected, the voltage value at output "M" breaks down to an undefined value.



ATTENTION

Never connect more than one main (HE 080 / HE 082) and 7 off site emergency buttons (HE 081).

Figure 21: Voltage main emergency switch "M" (Alarm)

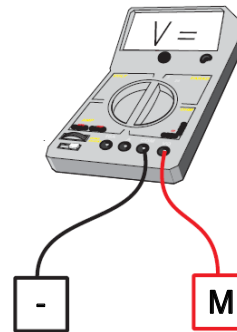

➤ Only during SHEV-alarm:

- During mains operation: approx. 24 V DC.
- During emergency power operation: approx. 21 V DC to 28.6 V DC.

"B1" supplies the plus potential for the closed-circuit current loop, which monitors the switch wires of the emergency switch HE 080 / HE 082. The closed-circuit current window lies between 50 μ A and approx. 5 mA. If the value of the closed-circuit current is not within this tolerance, the control panel is triggered. The terminating resistor must be looped in at the last switch wire connection point as marked in the schemes. The loop is monitored for disconnection and short circuit. If no switches are connected, the resistor must be directly installed in the control panel (SHEV[®] 6 RSV) (delivery state).

Figure 22: Voltage main control unit connection "B1"

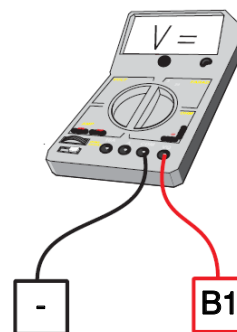

Fault Finding

- During mains and emergency power operation: approximately 18 V DC.



ATTENTION

If the terminal resistor remains in the control panel, the manual control device (HE 080 / HE 081 / HE 082) only allows triggering by "RA". Loop monitoring does not take place!

Figure 23: Closed-circuit current main emergency button connection "B1"

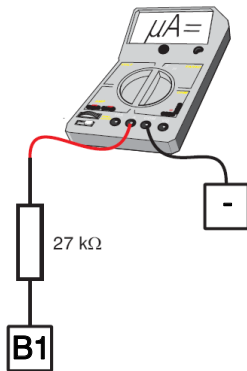

- 600 μ A to 700 μ A

By clamping the potential of terminal connector "B1" onto terminal connector "RZ", a RESET of the system is effectuated.



INFO

The SHEV® 6 RSV is equipped with a reset function (see chapter 1.5.1 "SHEV-switch reset function" on page 10).

6.2.6 Checking smoke detector connection



Similar to terminal clamp "B1", terminal clamp "B2" supplies a plus potential that, with the terminal resistor switched against minus, results in a defined closed-circuit current loop. The terminal resistor closes the loop at the last smoke detector (see Figure 7: "Wiring diagram smoke detector" on page 16). Only smoke detectors of the type RM 3000 or RM 2860 should be connected. If no smoke detectors are connected, the terminal resistor will be directly clamped in the control panel (delivery state). In standard wiring, RA is without function.

Figure 24: Voltage main control unit connection "B1"

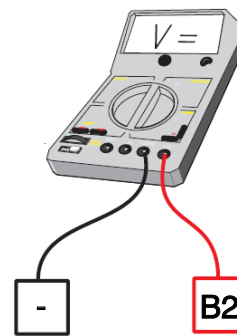

- During mains and emergency power operation: approx. 18 V DC.



ATTENTION

If the terminal resistor remains in the control panel, loop monitoring does not take place!

Figure 25: Loop current smoke detector connection

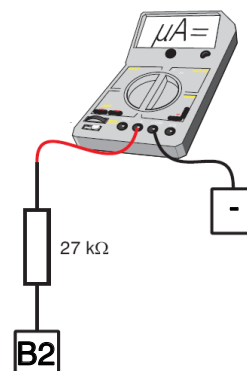

- 600 μ A to 700 μ A

6.2.7 Checking output for an on-site SHE release contact (for example Fire alarm)

Fault Finding

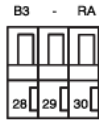

ATTENTION

If the terminal resistor remains in the control panel, loop monitoring does not take place!

The output for a on-site contact (N/C contact) is achieved by the terminal clamps “B3” and “-”. The monitoring concept is identical to the other monitoring loops of the “B1” and “B2” outputs. For example, a heat detector with volt-free N/C contact can be connected to the output “B3” (see Figure 12: “Wiring diagram contact FAS” on page 18). If no contacts are connected, the terminal resistor will be directly clamped in the control panel (delivery state!).

Figure 26: Voltage on-site SHE triggering contacts (e. g. FAS)

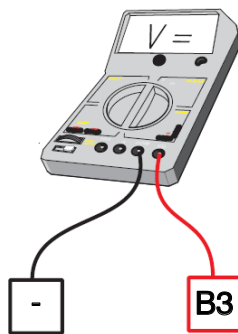

⚡ During mains and emergency power operation: approx. 18 V DC.

Figure 27: Loop current on-site SHE triggering contacts (e. g. FAS)

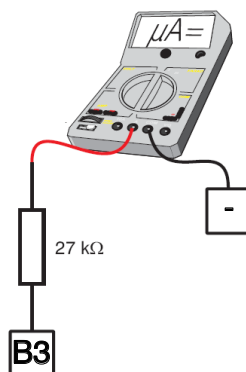

⚡ 600 µA to 700 µA

Fault Finding

6.3 FAQ — Frequently Asked Questions

- Question: Why is there still an error message despite inserting and connecting of the battery and placing of the main power line?
 - Answer: To take the control unit (including emergency power supply) into operation you must press the RESET-button for more then 5 seconds.

- Question: Why does the yellow LED (common fault) lights, although all recognizable and known causes have been eliminated?
 - Answers:
 - » 1. The maintenance counter is expired and must be set back, via SIMON-link.
 - » 2. Battery deep discharge: If the error-message can not be set back by pressing the RESET-button for more than 5 seconds the battery must be replaced.

- Question: Why do I not get a fault indication when the battery is not plugged in or the connection cables are disconnected? (yellow LED???)
 - Answer: The battery assessment is carried out in cycles and can last up to maximum 8 minutes. In the event of a battery fault, the yellow LED is set and additionally the green LED is turned flashing for better distinction. The malformation "Battery defect or not connected" goes out without time delay.

- Question: Battery change with or without metal plate?
 - Answer: The battery pack can be changed entirely and is available as a replacement set from the factory. On site un-approved batteries render the warranty invalid.

- Question: What does the VDS-number on the battery means? Is this a special SHEV-number?
 - Answer: The VDS number on the battery is also suitable for use in the SHEV-area.

- Question: Why does the yellow LED in HE 080 / HE 082 flash constantly during SHEV-triggering?
 - Answer: The flashing of the yellow LED during SHEV-alarm at the main emergency button HE 080 / HE 082 is initiated by the switch itself and can not be changed.

- Question: What is the terminal clamp No. 16?
 - Answer: The terminal clamp 16 is unassigned and does not have any function in the current software status.

- Question: Which protection type: IP 54 or IP 66?
 - Answers:
 - » 1.The housing offers protection type IP 66. The protection type does not change with cable glands of protection type IP 66.
 - » 2. Cable glands of protection type 54 reduce the overall protection type to IP 54.

Notes
