

BA PA-K-50/xxx PA-K-65/xxx EN 1.0

For further information
please visit our product-
website:



[short.simon-protec.com/
pak50en](https://short.simon-protec.com/pak50en)



Copyright by SIMON PROtec Systems GmbH
Subject to technical changes and errors. All figures are exemplary.



SIMON PROtec Systems GmbH • Medienstraße 8 • D-94036 Passau
☎ +49 (0) 851 988 70-0 • 📠 +49 (0) 851 988 70-70 • info@simon-protec.com • www.simon-protec.com



**These operating instructions are only valid with the supplied
supplementary sheet „Safety instructions and Warranty conditions“!**

Table of Contents

1.	Figures	3
2.	General.....	4
2.1.	Use for the intended purpose.....	4
3.	Mounting.....	4
3.1.	Safety instructions.....	4
3.2.	Mechanical connection.....	4
3.2.1.	Mounting the lower brackets.....	4
3.2.2.	Upper bracket K-K50-OK / K-K-OK-SK	5
3.2.3.	Incorrect positioning of K-K50-OK	5
3.2.4.	Alignment of K-K-OK-SK	5
3.2.5.	Upper bracket K-K50-AKI	6
3.2.6.	Inward opening top/bottom hung window, mounting on the blind frame.....	6
3.2.7.	Outward opening top/bottom hung window / roof window, mounting on the blind frame.....	7
3.2.8.	Inward opening top/bottom hung window, mounting on the sash.....	7
3.2.9.	Inward opening bottom hung window, mounting on the sash – K-K50-FLEX.....	8
3.2.10.	Side hung window	8
3.2.11.	Calculate force / stroke.....	9
3.2.12.	Permissible tractive and pushing force.....	9
3.3.	Electrical connection	10
3.3.1.	Power supply	10
3.3.2.	Feedback – volt-free contact	10
3.3.3.	Preparation for installation.....	10
3.3.4.	SICO PLUG Assignment	10
3.3.5.	Single operation.....	10
3.3.6.	Synchronous operation.....	10
3.3.7.	Double connection (DA version)	10
3.4.	Setting options	11
3.4.1.	Synchronous actuators.....	11
3.4.2.	Zero point/RESET-range.....	11
3.4.3.	Operating modes synchronous actuator.....	11
3.5.	Manual setting.....	11
3.5.1.	MASTER/SLAVE setting.....	11
3.5.2.	RESET-run	11
4.	Technical data	12

Figures

1. Figures

Figure 1: Actuator dimensions
PA-K-50 / PA-K-65

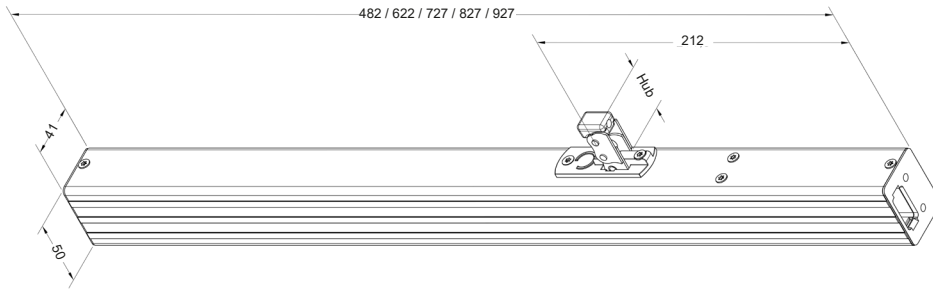

Figure 2: Upper bracket K-K50-OK



Figure 3: Upper bracket K-K-OK-SK

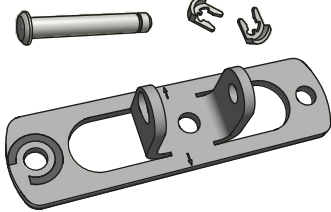

Figure 4: Lower bracket K-K50-A

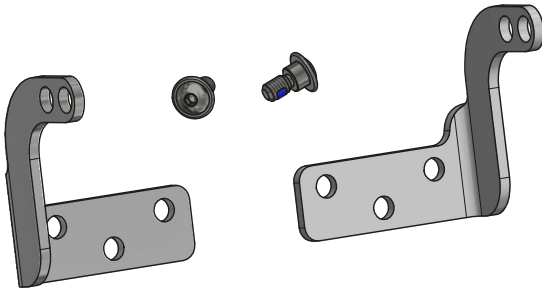

Figure 5: Lower bracket K-K50-K

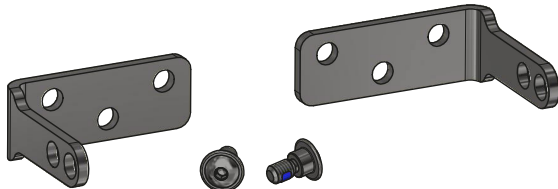

Figure 6: Lower bracket K-K50-FLEX

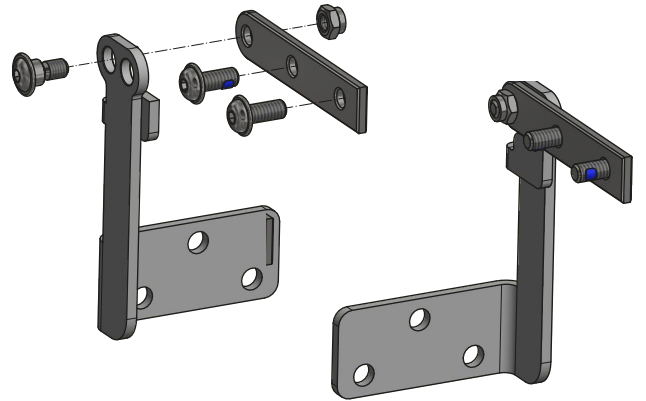

Figure 7: Insertion bracket inside K-K50-AKI

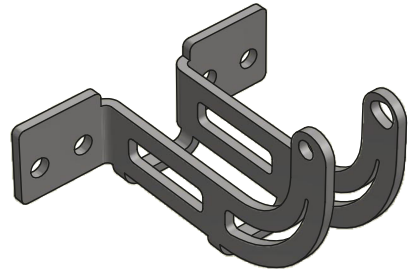
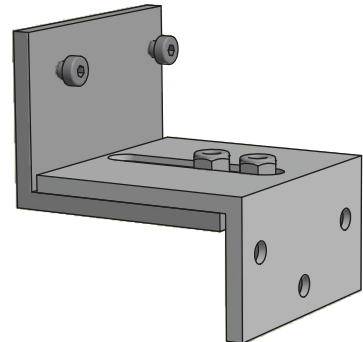

Figure 8: Supporting bracket inside K-K50-SKI



2. General

2.1. Use for the intended purpose

See supplementary sheet „Safety instructions and Warranty conditions“!

3. Mounting

3.1. Safety instructions

See supplementary sheet „Safety instructions and Warranty conditions“!

3.2. Mechanical connection



ATTENTION

All dimensions given in this chapter are minimum specifications and may vary depending on the type and design of the window.

Depending on the mounting position and shape of the window or building cover you need different combinations of brackets in order to mount the actuator. The brackets (see page 3) have to be ordered separately.



ATTENTION

Consider the static properties of the frame when installing the actuator.

Use appropriate fastenings depending on the material of the window.

Fastenings are not included in the delivery scope.

- Before mounting the actuator, check that the chain is extended a small distance.
- To achieve a good sealing of the window, check before mounting the actuator that after installation the chain of the actuator is extended a little, but not more than 25 mm after installation, otherwise the proper working of the electronic zero-reset cannot be guaranteed.

3.2.1. Mounting the lower brackets

- Determine the mounting position of the brackets so that the chain of the actuator does not collide with the window frame or sash in any opening position of the window and that the position of the chain is in the middle of the window.
- Mount the brackets with screws suitable for the respective window (screws not included in delivery), see page 3.
- Insert the actuator into the mounting brackets (K-K50-A, K-K50-K or K-K50-FLEX) and fix it with the self-locking flange head screws.

Figure 9: K-K50-A

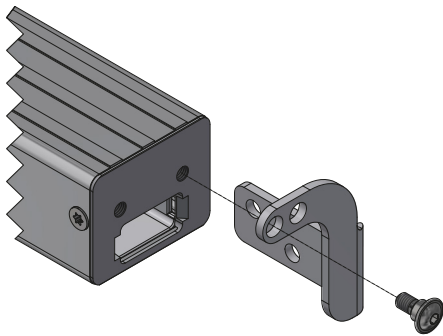

Figure 10: K-K50-K

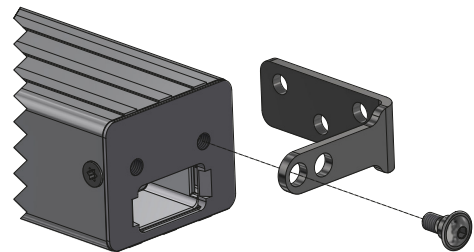
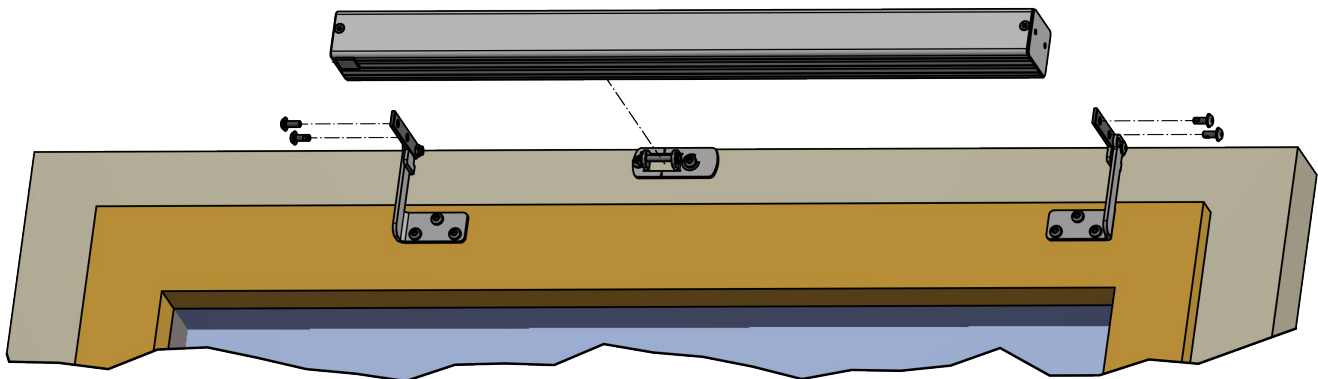

Figure 11: K-K50-FLEX



General / Mounting

3.2.2. Upper bracket K-K50-OK / K-K-OK-SK



ATTENTION

The upper bracket must always be aligned so that the SIMON logo of the bracket and the chain actuator are on the same side.



INFORMATION

Centerline mark to align the bracket in the middle of the wing (solo variant) or at 1/4 distance from the left and right edge (parallel variant).

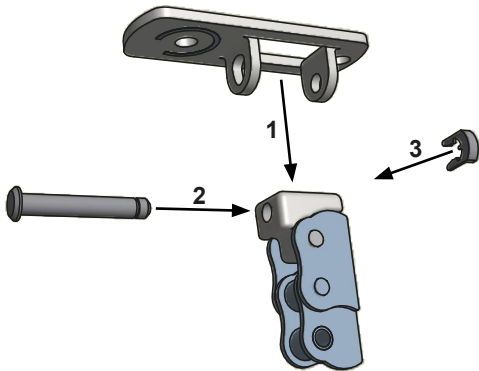
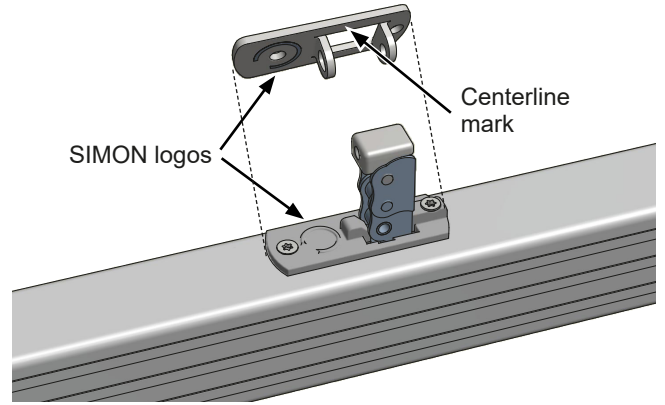

- Extend the chain about 100 mm and connect the chain end with the K-K50-OK (1). Insert in the mounting bolt from the side with the logo (2) and secure it on the other side with the retaining ring (3).

3.2.3. Incorrect positioning of K-K50-OK



ATTENTION

The upper bracket K-K50-OK must not be mounted rotated!

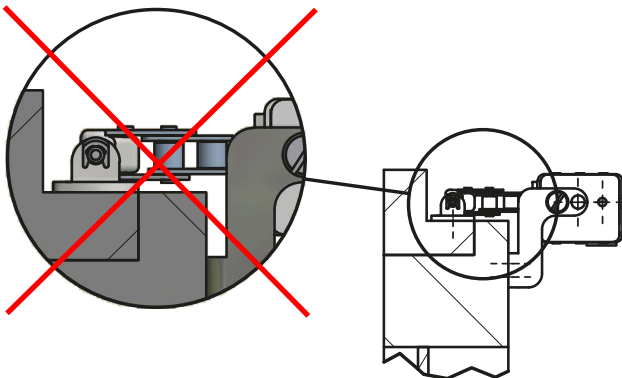

INFORMATION

This mounting variant is possible with the alternative upper bracket K-K-OK-SK.

3.2.4. Alignment of K-K-OK-SK



ATTENTION

The combination of actuator and bracket may only be used with this alignment to each other.

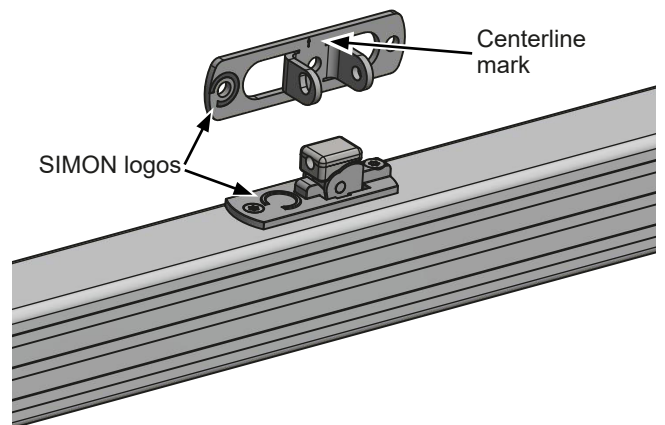

Mounting

3.2.5. Upper bracket K-K50-AKI



ATTENTION

The upper bracket must always be aligned so that the SIMON logo of the bracket and the chain actuator are on the same side.

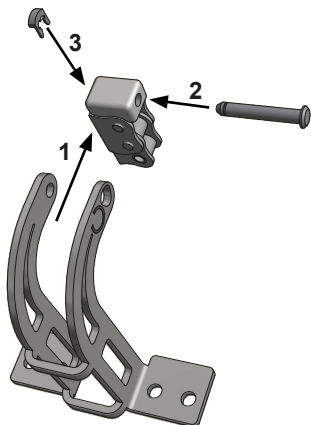
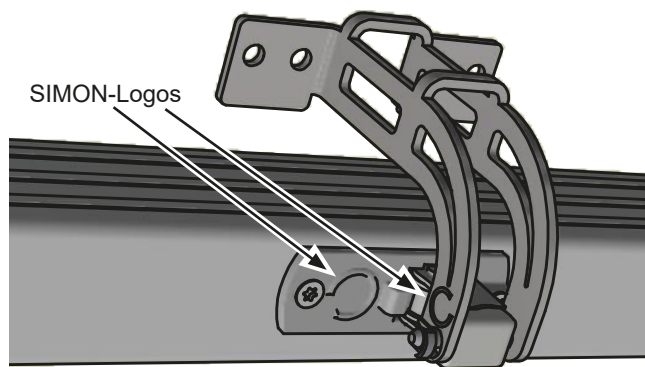

- Extend the chain about 100 mm and connect the chain end with the K-K50-OK (1). Insert the mounting bolt from the side with logo (2) and secure it on the other side with the retaining ring (3).

3.2.6. Inward opening top/bottom hung window, mounting on the window frame

Figure 12: Bottom hung wing

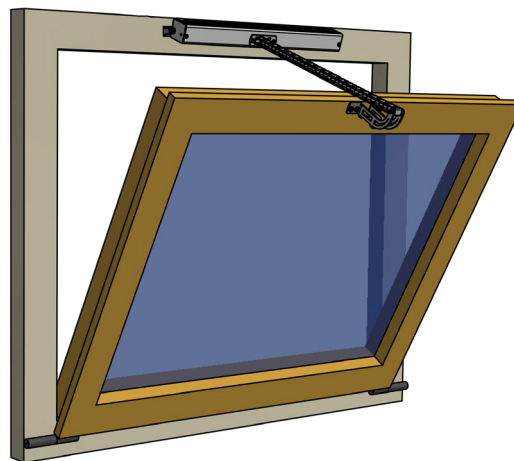
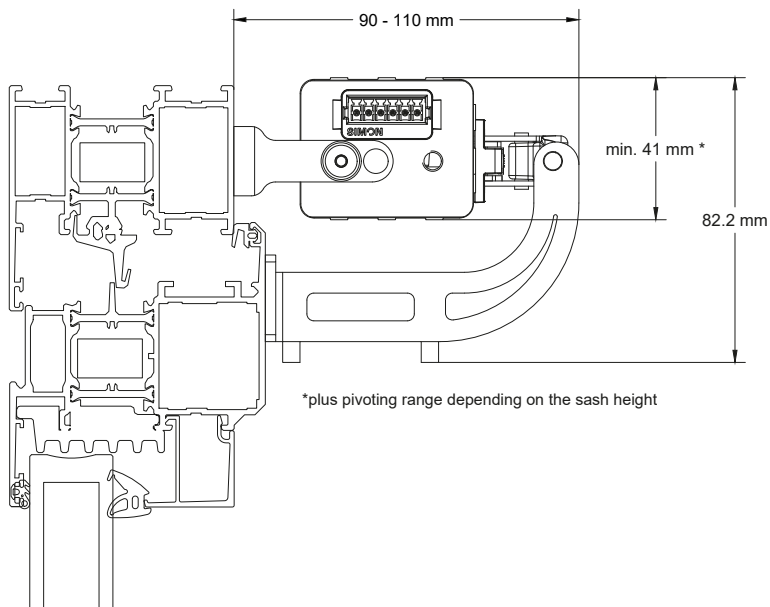

Mounting

3.2.7. Outward opening top/bottom hung window / roof window, mounting on the window frame

Figure 13: Top hung wing

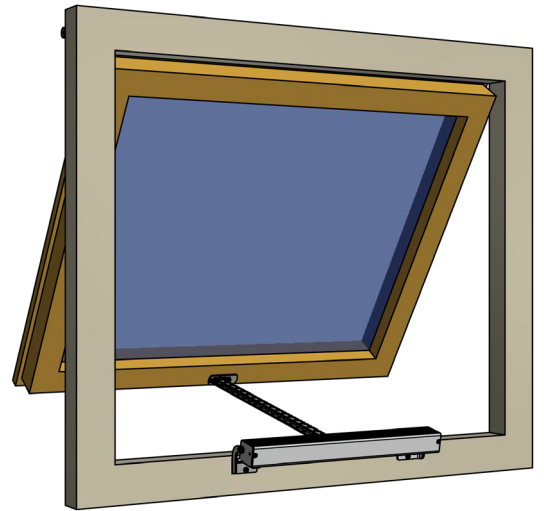
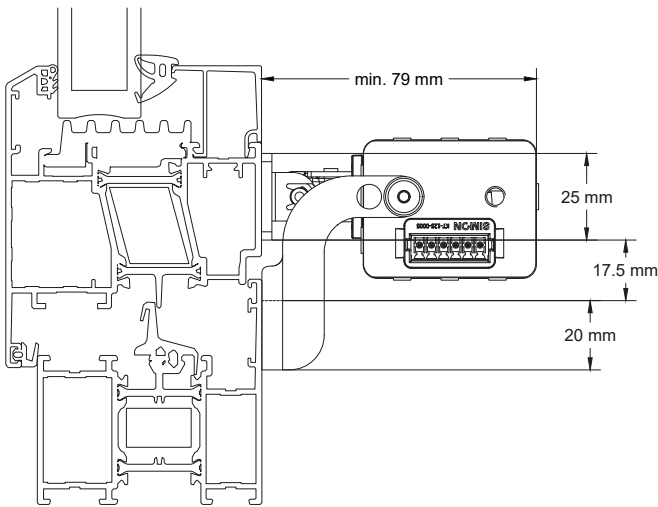

3.2.8. Inward opening top/bottom hung window, mounting on the sash

Figure 14: Bottom hung wing

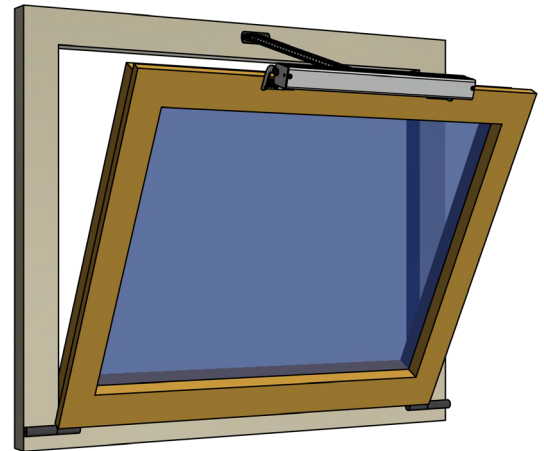
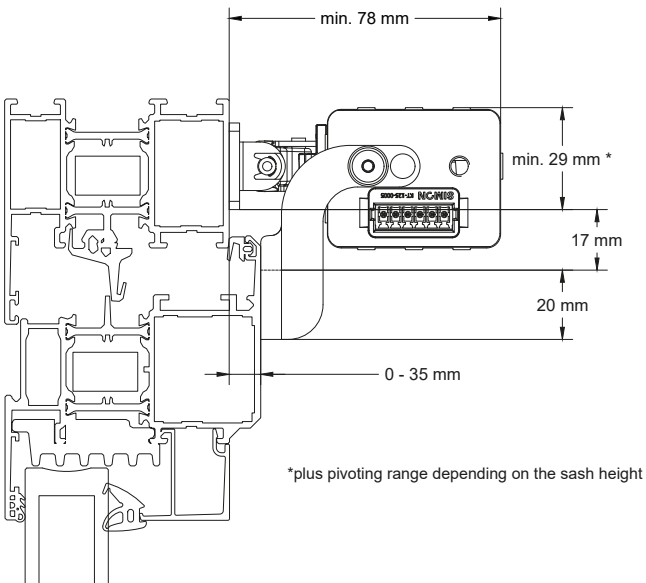

Mounting

3.2.9. Inward opening bottom hung window, mounting on the sash – K-K50-FLEX

Figure 15: Bottom hung wing

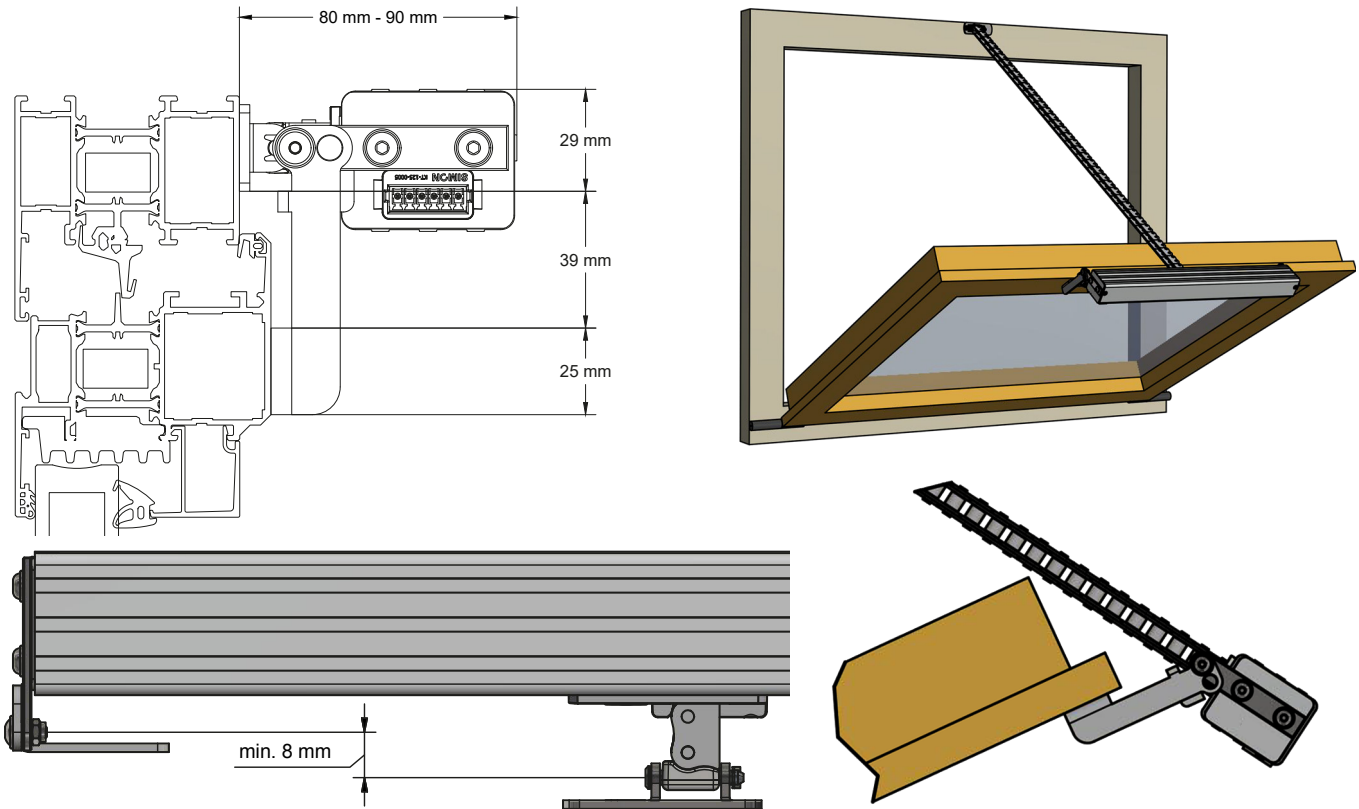

3.2.10. Side hung window



ATTENTION

The chain actuator may only be installed upright (with the motor side up) on DIN Left windows!

Figure 16: Mounted on window frame — K-K50-AKI

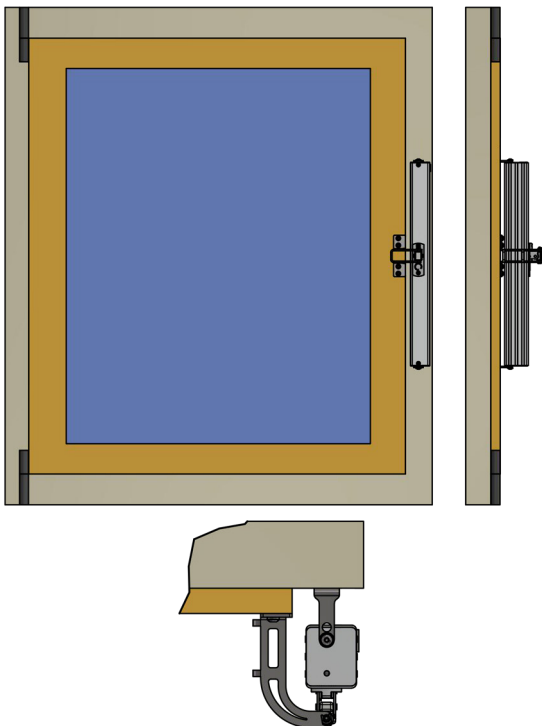
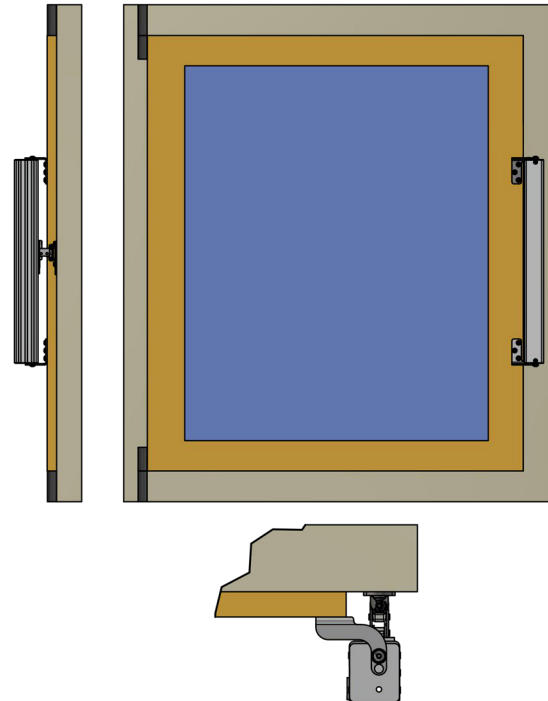
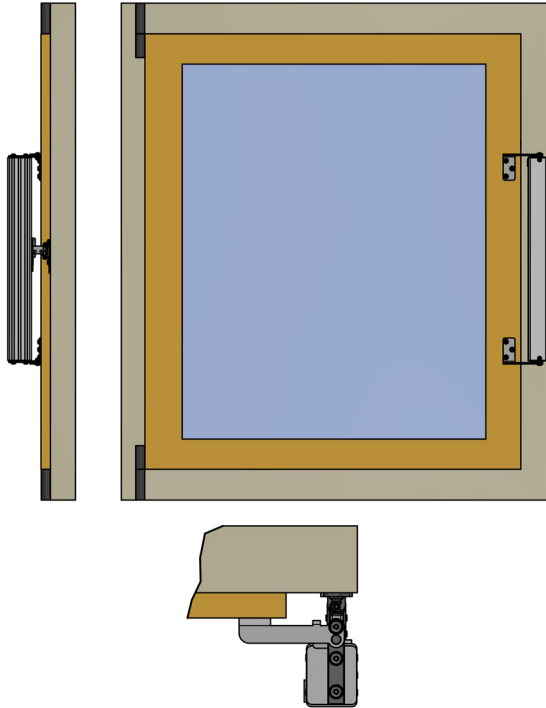

Figure 17: Mounted on sash — K-K50-A



Mounting

Figure 18: Mounted on sash — K-K50-FLEX



3.2.11. Calculate force / stroke

This calculation is only valid for vertically installed wall windows. For other installation options, a more detailed calculation must be made, which we can assist with.

- F := force of the actuator [N]
- S := stroke of the actuator [mm]
- H := height of the window sash [mm]
- G := weight of the window sash [kg]

Required force of the actuator at a given stroke:

$$F = (G / 2) \times (S : H) \times 10$$

$$= (G \times S \times 5) : H$$

Maximum possible stroke of the actuator at a given force:

$$S = (2 \times F \times H) : (G \times 10)$$

$$= (F \times H) : (G \times 5)$$

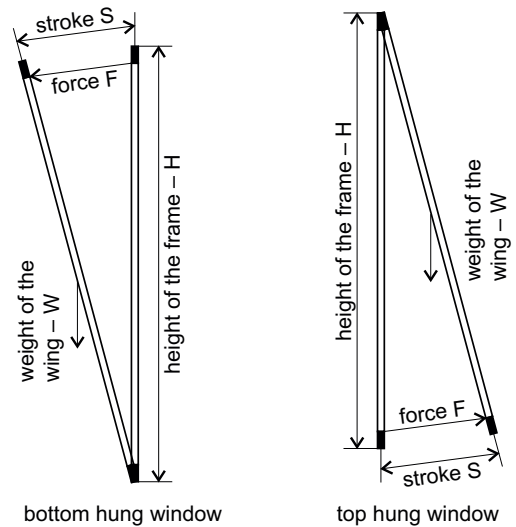

3.2.12. Permissible tractive and pushing force



ATTENTION – PA-K-50

Permissible application (pushing force):

- Roof window: max. stroke 500 mm
- Top hung window: max. stroke 600 mm



ATTENTION – PA-K-65

Permissible application (pushing force):

- Roof window: max. stroke 400 mm
- Top hung window: max. stroke 500 mm

Figure 19: Permissible tractive and pushing force

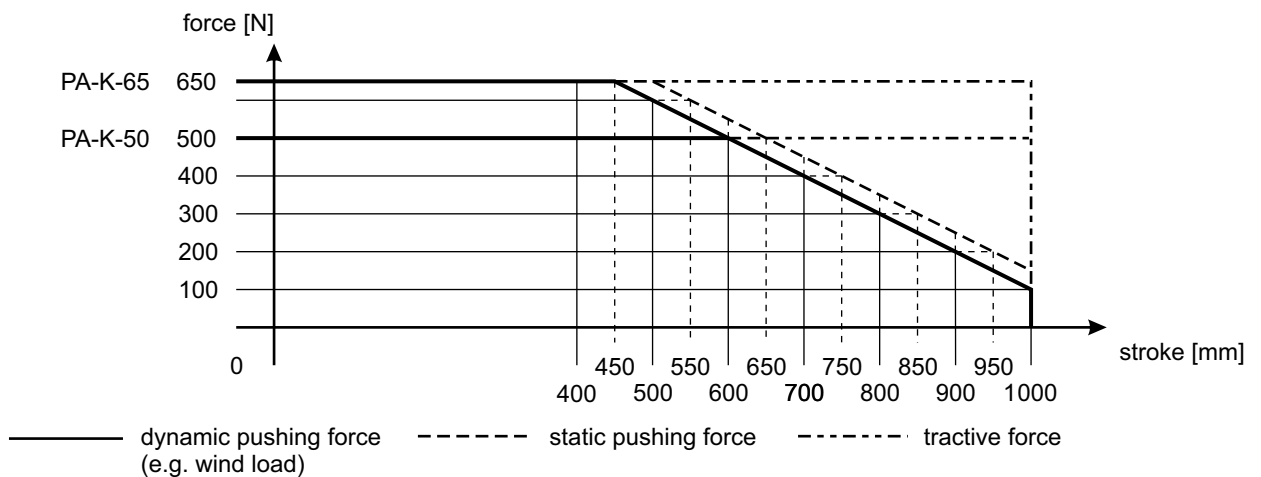

Mounting

3.3. Electrical connection

See the attached sheet "safety instructions and warranty conditions"!



ATTENTION

Unused wires must be electrically insulated.

The wires **C1** and **C2** must not be connected to each other during normal operation.

3.3.1. Power supply

The supply voltage must be dimensioned sufficiently for the actuator. Voltage and current must fit the specifications on the type label.

3.3.2. Feedback – volt-free contact

The normally open contact (NO1, NO2) is activated in direction "CLOSE" when the actuator is cut off in end position "CLOSE". The message is stroke-dependent and can be evaluated as a "CLOSED" message.

3.3.3. Preparation for installation

Before starting the installation, the required connection cable must be assembled. For this purpose use the plug included in the scope of delivery (see instructions in the accessory bag with SICO PLUG). For NSHEV according to EN 12101-2, the silicone connecting cable approved by the manufacturer must be used.



3.3.4. SICO PLUG Assignment

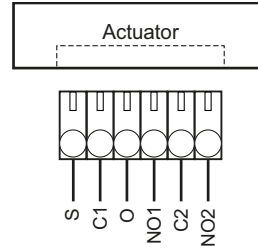

3.3.5. Single operation

➤ Connect wires according to the wiring diagram.

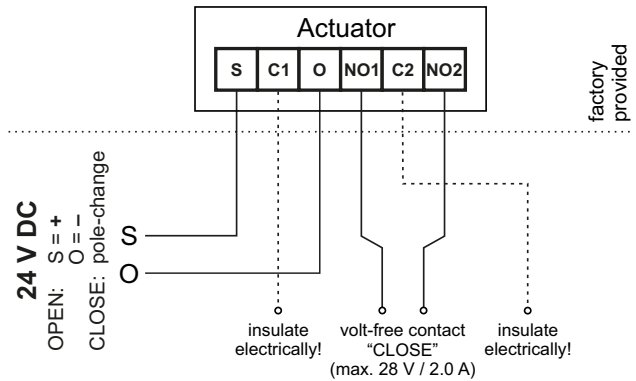

3.3.6. Synchronous operation

➤ Connect wires according to the wiring diagram.

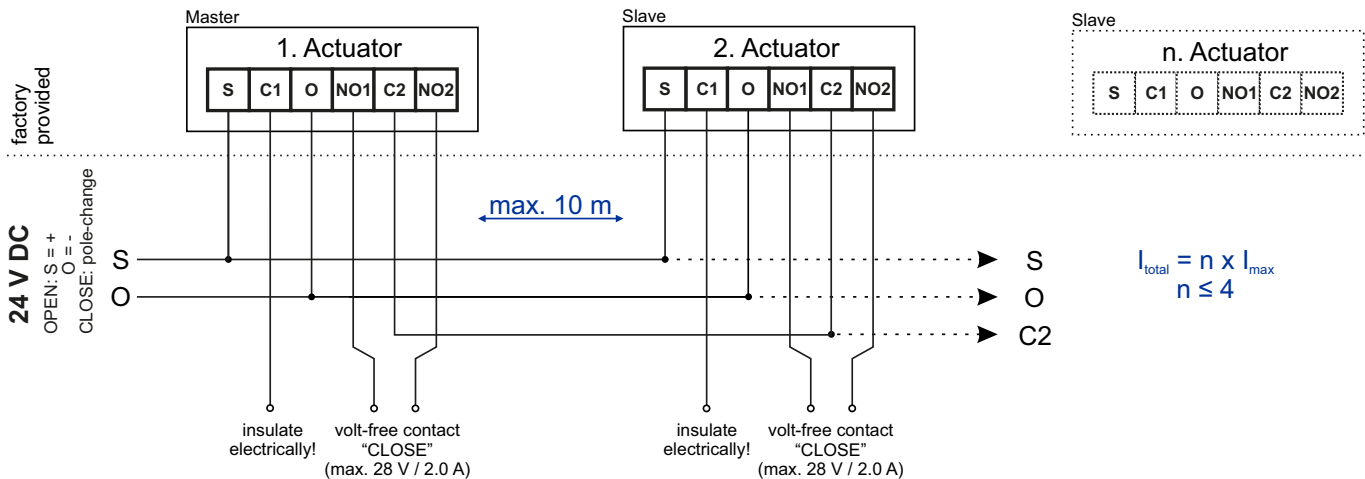

3.3.7. Double connection (DA version)



ATTENTION

For actuators with double connection in synchronous operation, connect only the wires S, O and C2 with each other after parameterisation! Electrically insulate C1 as well as NO1 and NO2 of the SLAVE actuator.

Mounting

3.4. Setting options

You can set **single operation** or **synchronous operation mode MASTER / SLAVE** via **SICO LINK** or manually.

Figure 20: Interface for SICO LINK

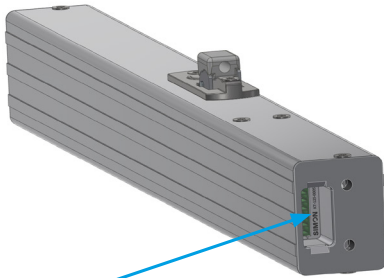

Connection e.g. for SICO-USB-110

Figure 21: Stroke behaviour

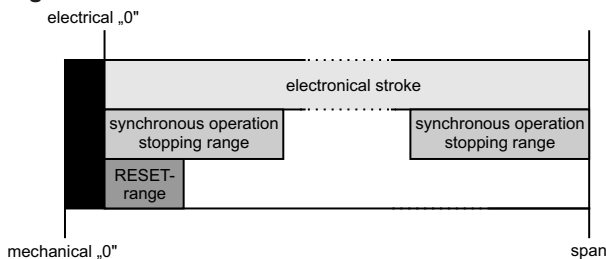

RESET-range: When the actuator is cut off on overload within the RESET-range, the electronic zero point will be set new.

Synchronous operation stopping range: If an actuator cuts off in synchronous operation in direction "OPEN" or "CLOSE" within the **stopping range**, the remaining actuators continue to run until cutoff in the respective end position.

3.4.1. Synchronous actuators

The synchronous actuators of the PA-K-50 / PA-K-65 series are identified by the suffix „S" in the part number (e. g. PA-K-50/600-S).

3.4.2. Zero point/RESET-range

It's necessary to reset the zero point, if the closed position of the actuator is out of the RESET-range after installation. (SICO LINK / RESET-run).

3.4.3. Operating modes synchronous actuator

If a synchronous actuator is to be used as a single actuator, the operating mode must be set to "Single operation" (SICO LINK or RESET-run) – factory setting.

If several actuators are to be used in synchronous operation, one actuator must be set to "Synchro Master" and the remaining actuators to "Slave" (SICO LINK or manual MASTER / SLAVE setting).



ATTENTION

In order to recalibrate the synchronous function, the actuator must be fully closed in the reset range after max. 50 cycles.

3.5. Manual setting

3.5.1. MASTER / SLAVE setting



ATTENTION

Manual setting: One MASTER and one SLAVE possible.

SICO LINK: One MASTER and up to three SLAVES possible.

- Drive the actuator in direction "CLOSE" (**S**="–" **O**="+") and let it cut off in the end position. If the actuator does not reach the „mechanical ZERO" position due to its mounting position, a RESET-run must be performed.
- Leave the actuator energized!
- Connect the wires **C1** and **C2** directly. A relay click can be heard.
 - ◆ After 5 seconds you can hear a relay click, the actuator is set to MASTER with one connected SLAVE. Separate wires.
 - ◆ After 10 seconds another relay click can be heard, the actuator is now set to SLAVE. Separate wires.
- Disconnect the actuator from power supply!
- Connect the two actuators according to chapter 3.3.6: „Synchronous operation" on page 10.

3.5.2. RESET-run

A RESET-run should be carried out,

- if the opening width of the closed actuator at the window is outside the RESET-range.,
- if the MASTER / SLAVE setting needs to be reset.
- Disconnect the actuator(s) from power supply!
- Connect the wires **C1** and **C2** of each actuator directly with each other.
- Drive each actuator in direction "CLOSE" (**S**="–" **O**="+") and let it be cut-off in the end position.
- Again disconnect actuator(s) from power supply and disconnect the wires **C1** and **C2**.
 - The zero point is set.
 - In case of "synchro capable" actuators, the operating mode is reset to "single operation" by the RESET-run. In this mode, the actuators can be operated standalone.

Technical data

4. Technical data

Table 1: Electrical characteristics

Actuator type	PA-K-50/xxx	PA-K-65/xxx
Rate voltage	24 V DC	
Permissible rated voltage range	24 V DC \pm 15 %	
Ripple of rated voltage Vpp	max. 500 mV	
Undervoltage detection	Yes	
Rated current ⁽¹⁾	1.4 A	1.9 A
Current consumption after cut-off (closed current)	35 mA	
Cut-off via	built-in electronic overload cut-off	
Maximum permissible number of actuators connected in parallel (with separate wiring)	4	
Maximum permissible number of actuators connected in parallel (with through-wiring via double connection)	2	
Cable length between two actuators in synchro mode	max. 10 m	
Protection class	II	

(1) Maximum current consumption with nominal load.

Table 2: Feedback contact

Actuator type	PA-K-50/xxx	PA-K-65/xxx
Rated voltage	24 V DC	
Relay contact load	1 A	



ATTENTION

The maximum load capacity of the contact must not be exceeded.

Technical data

Table 3: Connection and operation

Actuator type	PA-K-50/xxx	PA-K-65/xxx
Recommended connection cable	6 × 0.75 mm ²	
Pause time during change of direction ⁽¹⁾	min. 500 ms	
Switch-on duration	ED 30 (Short-term operation: 3 of 10 Min.)	ED 20 (Short-term operation: 2 of 10 Min.)
Stability of opening and closing cycles	> 11.000	
Sound level ⁽²⁾	< 50 dB (A)	
Deadlock according to prEN 12101-9/ISO 21927-9	allowed	
Multiple triggering after stop	allowed	
Maintenance	See supplementary sheet "Safety instructions and Warranty conditions"!	

(1) For the change of direction (pole reversal) it is necessary that the power supply ensures a pause time (zero-volt range) of at least 500 ms.

(2) Measured at a distance of one metre under normal conditions.

Figure 22: Zero voltage range at changing of direction

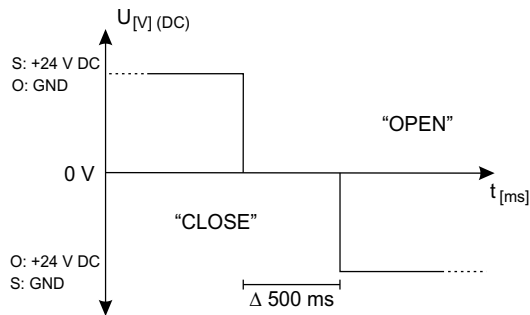

ATTENTION

Voltage stability / quality: only defined cut-off processes are permitted (cut-off time from rated voltage 24 V to 0 V in $t < 10 \text{ ms}$).

This applies in particular for switching operations from primary (mains operation) to secondary energy source (emergency power batteries).

Table 4: Connection and operation

Actuator type	PA-K-50/xxx	PA-K-65/xxx
Rated operating temperature	20 °C	
Permissible ambient temperature range	from -5 to 75 °C	
Temperature - stability (SHE)	300 °C	
Ingress protection	IP 32	
Usage range	Central European environmental conditions $\leq 2,000$ metres above sea level	

Technical data

Table 5: Approvals and certificates

Actuator type	PA-K-50/xxx	PA-K-65/xxx
CE-compliant	In accordance with EMC directive 2014 / 30 / EU and the low voltage directive 2014 / 35 / EU	
Further approvals	On request (e.g. NSHEV according to EN 12101-2)	

Table 6: Mechanical characteristics

Actuator type	PA-K-50/xxx	PA-K-65/xxx
Maximum pushing force ⁽¹⁾	500 N	650 N
Maximum pull force ⁽²⁾	500 N	650 N
Condition of loading	Opening against nominal load Closing with nominal load support	
Nominal locking force	≤ 2000 N in "OPEN" and "CLOSE"	
Nominal stroke for pulling application ⁽³⁾	300 mm / 600 mm / 800 mm / 1000 mm / 1200 mm	
Nominal stroke for pushing application	300 mm / 600 mm	300 mm / 450 mm
Stroke speed at nominal load ⁽⁴⁾	10.5 mm/s	8.5 mm/s
Material / Surface housing	Alu E6/EV1 Coatings in all RAL and DB colours possible	
Material chain	corrosion-resistant monostable steel chain, silver nickel plated	
Dimensions (L × W × H) ⁽⁵⁾	300 mm Stroke: 482 × 50 × 41 mm 600 mm Stroke: 622 × 50 × 41 mm 800 mm Stroke: 727 × 50 × 41 mm 1 000 mm Stroke: 827 × 50 × 41 mm 1 200 mm Stroke: 927 × 50 × 41 mm	
Weight approx.	1.81 kg / 2.10 kg / 2.50 kg / 2.77 kg / 3.10 kg	

(1) Only under optimum conditions. Pushing force can be parameterized via SICO LINK.

(2) Tractive for parameterizable via SICO LINK.

(3) The nominal stroke can deviate by ± 3 % due to mechanical damping, but no more than 20 mm.

(4) In relation to a stroke of 600 mm; tolerance ± 10%.

(5) Plus chain exit (20 mm).